

OXY-FLEX Series

Oxygen Transmitter

PST offers a compact and cost-effective zirconia transmitter to measure percentage level oxygen in combustion processes, excess air monitoring, bakery ovens, and many more applications.

The unit is configurable to measure either 0.1...25 % or 0.1...100 % oxygen and offers manual or automatic calibration to suit the customer's needs.

The probe can be mounted directly on the housing unit or a shielded cable. The OXY-FLEX is easy to install and integrate into existing systems as no specialist software is required.



Highlights

- Configurable outputs: 4-20 mA and 0...10 V DC or RS232 comms interface
- Cycling 3.3 V DC logic output allows direct monitoring of the O₂ sensor for diagnostic purposes
- Can be calibrated in normal air, 20.7 % O₂, or in any other known O₂ concentration
- Selectable output filtering allows fast and dynamic or slow and stable output
- Externally triggered automatic or manual calibration
- Sample temperature from -100 °C / -148 °F to +400 °C / 750 °F
- IP66 certified enclosure in either aluminum or stainless-steel
- Certified CE, UKCA, ISO9001

Applications

- Compressed air class 1 to Class 6 dryers
- Breathing air
- Inert and bulk gases
- Welding gases
- Combustion optimization
- Pharmaceutical oxygen control
- Oil, gas and biomass boilers
- Composting
- Commercial baking ovens
- Oxygen generation

Product Dimensions

XZR200 with Aluminum housing

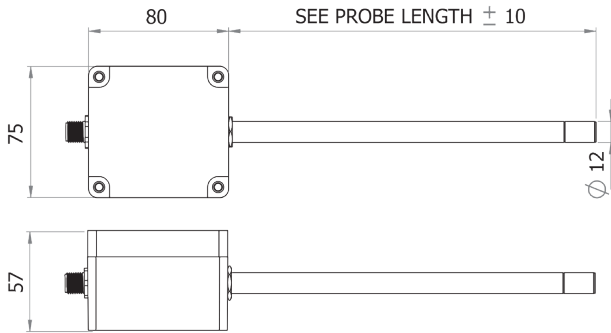

XZR201 with Aluminum housing with probe connected via shielded cable

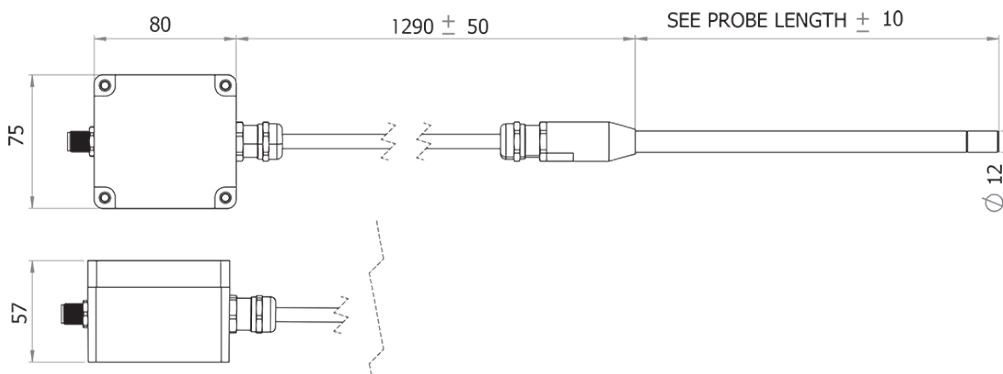

XZR210 with stainless-steel housing

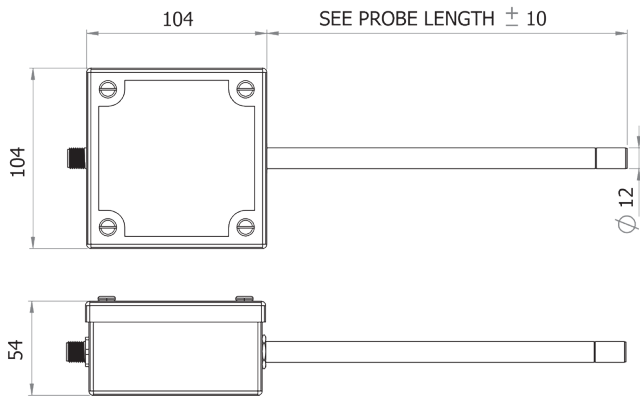

XZR211 with stainless-steel housing with probe connected via shielded cable

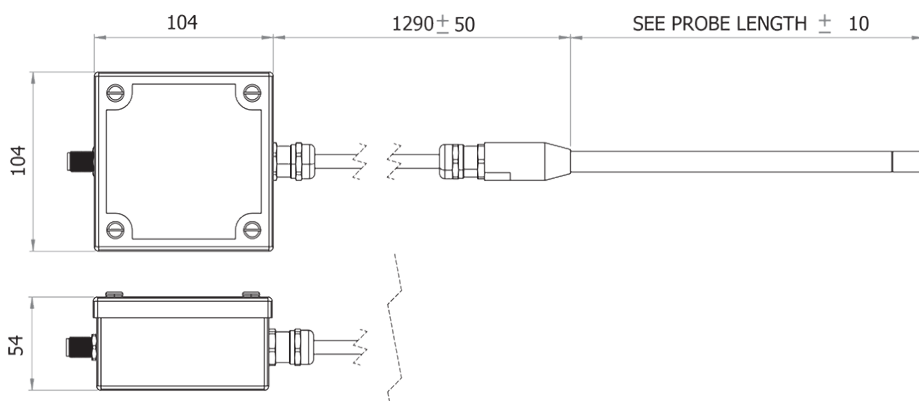

XZR Aluminum housing mounting

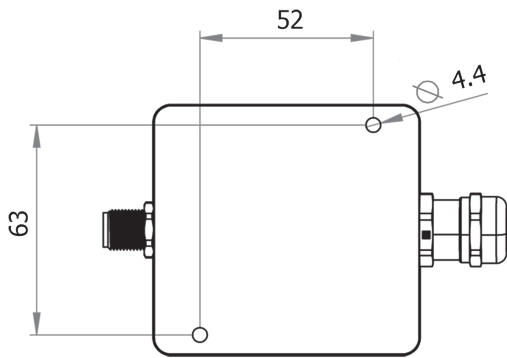

Mounting holes in the aluminum housing are accessible on removal of the lid.

Note: The XZR210, XZR211 housing cannot be mounted directly to a flat surface. The customer must use a suitable bracket of their own design.

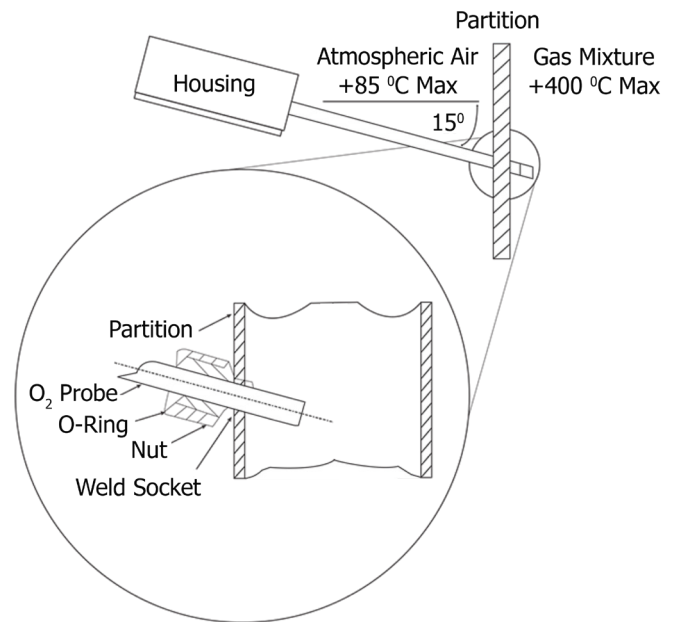

XZR Connections

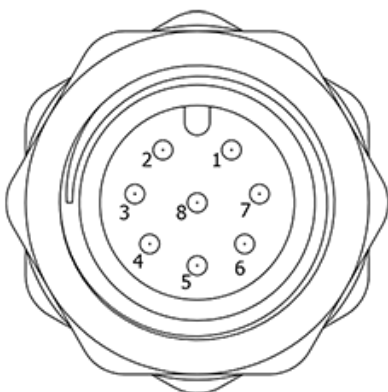

As seen from outside of housing.
Connector: M12, 8 Pin, A Coded

Sensor Connections	
Pin Number	Connection
1	24 V DC ± 10 %
2	Not Connected
3	0...10 V DC / RS232 Rx
4	4...20 mA / RS232 Tx
5	Cycle
6	Calibrate
7	GND (0 V DC)
8	Not Connected

Technical Specifications

Performance	
Measurement Technology	Zirconia
Gas	Oxygen
Measurement Range	0.1...25 % or 0.1...100 %
Output Resolution	0.01 V, 0.01 mA or 0.01 % O ₂
Accuracy (0-25%)	< 0.5 % O ₂
Accuracy (0-100%)	< 1 % O ₂
Response Time (T10-90)	< 15 seconds
Repeatability	< 0.5 %
Sample Flow Rate	0...10 m/sec
Sample Flow Effect (calibrated @ 0.5 l/min)	±0.1 % O ₂ (0 to 1 l/min)
Sample Pressure	Atmospheric*
Sample Temperature	Up to + 400 °C
Background Gas	Air, N ₂ , CO ₂ , Ar or combustion gas

Electrical Input / Output	
Supply Voltage	24 V DC, ±10 %
Supply Current	<1A Operating @ 24 V DC <2A Start-up @ 24 V DC
Analog Outputs	0...10 V DC, 4...20 mA
Comms Output	RS232

Mechanical Specifications	
Warm Up time	Approx. 10 minutes
Probe Dimensions	220, 400 or 600 mm (length) ø12 mm
Weight	< 0.5 kg
Wetted Materials	Stainless-steel
Process Connection	12 mm Swagelok® compression fitting or equivalent required
Ingress Protection	IP66
Housing Material	Waterproof die-cast aluminum or stainless-steel housing

Operating Conditions	
Ambient Temperature	-10...+85 °C (14...+185 °F)



Warning: Probe tip can be hot, do not touch

*The OXY-FLEX is designed to be operated at atmospheric pressures.

However, it is possible to measure in the range 0 to 25% O₂ at pressures up to 3 barg (43.5 psig) without damage to the unit.

The unit will require calibration at the operating pressure and a separate pressure transducer feeding into the control system may be required.



Caution: Prolonged operation below 0.1 % O₂ can damage the sensing element.

Order Information

Generate your specific part number using the convention shown below. Use only those letters and numbers that correspond to the switch and output options you require.

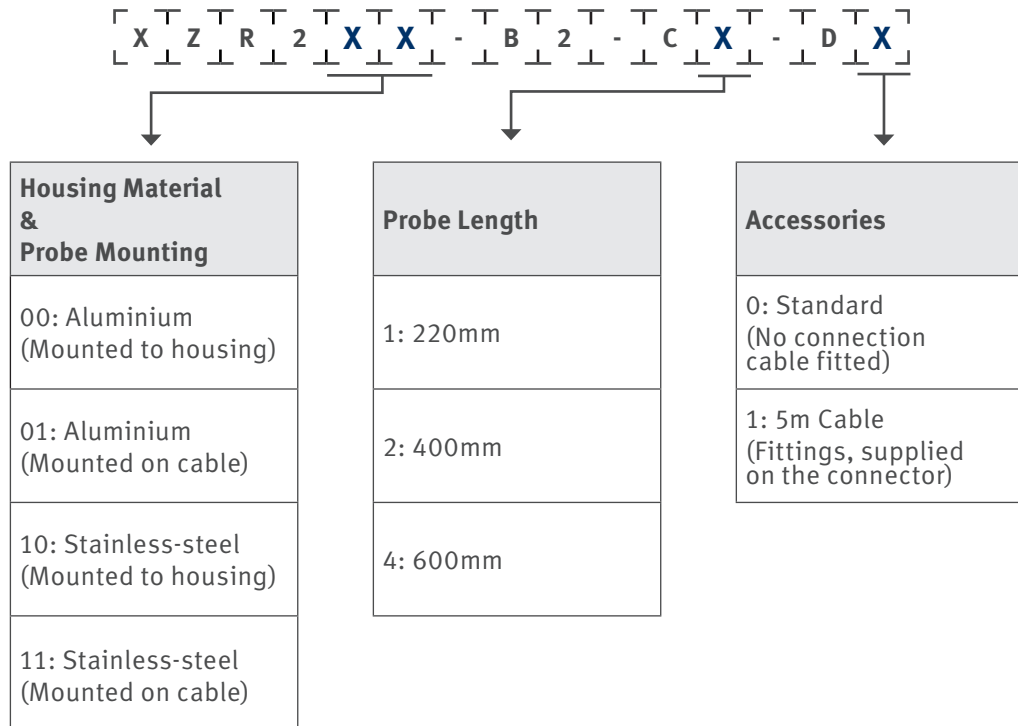

For example, if you require a transmitter in a stainless steel housing with a 600mm probe length and 5m cable, you would order: XZR210-B2-C4-D1

Process and Electrical Connectors

Part Number	Description
XZR200-PCON1	12mm (0.5") tube to ½” NPT(M) Stud – Bored through to 12mm (0.5") tube
XZR200-PCON2	12mm (0.5") tube to ½” ISO/BSP(T) Stud – Bored through to 12mm (0.5") tube
XZR200-PCON3	12mm (0.5") tube to ½” ISO/BSP(P) Stud – Bored through to 12mm (0.5") tube
XZR200-PCON4	12mm (0.5") tube to ½” N.B. tube (Weld) – Bored through to 12mm (0.5") tube
CON	Mating Connector. Binder 713 Series

! CAUTION
 Do not exceed maximum ratings and ensure sensor(s) are operated in accordance with their requirements. Carefully follow all wiring instructions as incorrect wiring can cause permanent damage to the device.

INFORMATION
 As customer applications are outside of PST control, the information provided is given without legal responsibility. Customers should test under their own conditions to ensure that the equipment is suitable for their intended application.

PST adopts a continuous development program which sometimes necessitates specification changes without notice.

For technical assistance or enquiries on other sensor options, please contact uk.sst.sales@processsensing.com