

SAT seal –Clamped Sanitary diaphragm seal type

Design description

Badotherm sanitary seals are designed for pressure, level and flow measurements in food & beverage and pharmaceutical industries where the formation of bacteria needs to be prevented by reducing or eliminating blind spaces where process product could remain and thus creating impurities, bacteria by e.g. fermentation. As such these seals allow for easy cleaning by means of either threaded or clamp quick couplings. All these seals and fill fluid are suitable for CIP (Cleaning In Process) applications.

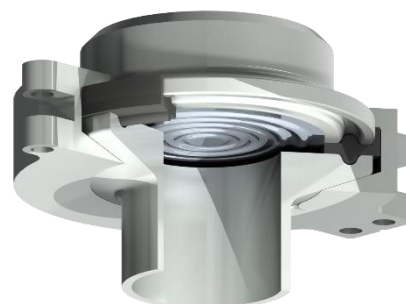

Body / diaphragm combinations

Housing materials	Diaphragm material		
	Upper / Lower	General name	UNS
AISI 316(L)	AISI 316L	S31600	1.4404
AISI 316	AISI 316	S31600	1.4435

Size and rating – ISO 2852

ISO 2852 (pipe standard per ISO 2037& BS 4825 part 1)		
Size	Rating	Type
DN25 to DN51	PN40	Clamped version (SAT)
DN63.5 to DN101.6	PN25	

Size and rating – DIN 32676

DIN 32676 (Pipe standard per DIN 11866 Reihe A, DIN 11850 Row 2)		
Size	Rating	Type
DN25 & DN50	PN40	Clamped version
DN65 to DN100	PN25	

DIN 32676 (Pipe standard per DIN 11866 Reihe B, DIN 11850 Row 1)		
Size	Rating	Type
42.4 to 60.3	PN40	Clamped version
76.1 & 88.9	PN25	

DIN 32676 (Pipe standard per DIN 11866 Reihe C, ASME BPE)		
Size	Rating	Type
1" to 2"	PN40	Clamped version
2.5 & 3"	PN25	

Size and rating – Varinline®

Size	Rating	Type
DN25 (1")	PN40	Type F (SA-V)
DN40-DN125 (1.5"-6")		Type N (SA-V)

Size and rating – Tankspud

Size	Rating	Type
4"	PN40	Industry standard and ISO 2852 clamped version (SA-TS)

Polymer coatings

Polymer coatings come in several types. The technical data on thickness and temperature limitation can be found in datasheet "polymer solutions" The applicable selection on BF seals are:

- PTFE coating
- ECTFE (Halar®) coating
- PFA coating
- FEP coating
- *PTFE sheet*

-> See datasheet "Polymer solutions"

Capillary tube and armor (protection)

The standard capillary mounting position is top side (axial) of the seal. Alternatively, the capillary can be placed at the side of the seal (radial). The standard tube material is TP316 (316SS). There are three options in ID of the capillary; 2mm, 1mm, and 0.7mm. Badotherm capillaries are always protected against mechanical forces by armor. This doubled shielded armor consist is standard AISI 304, and optionally AISI 316. Additionally, the armor could be protected with a PVC sleeve in white, black, optionally with ATEX114 approval to protect against dust and water ingress and possibly corrosive ambient atmosphere.

-> See datasheet "Capillary lines"

Cooling options

There are several ways to protect the instrument from elevated temperatures, such as the extended direct mount (EDM), a temperature reducer (TR) or by means of capillary.

-> See datasheet "cooling devices"

Roughness

The roughness of the sanitary diaphragm seals is very important. Basic roughness is achieved with mechanically polishing process. A lower roughness is achieved with mechanically polishing with electropolish finish. The surface finish (SF) reference are from the ASME BPE standard. The values are valid for wetted parts excluding the weld seam.

	Max Value	BPE
Mechanically polished surface	0.76 Ra	SF3
Electropolished surface	0.38 Ra	SF4

Instrument connections

The SA seals are designed to be direct mounted to a pressure gauges or a pressure transmitter. The leading instrument connection for the SA seals is G ½. However for vibrating application that are remoted mounted with a mounting bracket, a capillary a top mounted execution is available.

Halar® ECTFE is a registered trademark of the company Solvay Solexis

Gaskets

Gaskets for the sanitary seals can be supplied by Badotherm. However due to the high demands of the pharmaceutical and food processes the material should be specified clearly. Materials such as NBR, EPDM, FPM, PTFE or MVQ can be supplied.

Clamps

Clamped Sanitary seals are fixed to the process by clamps. The clamps can be ordered at Badotherm and supplied along with the diaphragm seal. The clamps of the SA-TS cannot be supplied.

Material Certification

Material traceability and related certification are applicable for all process wetted parts. Material certification possibilities depend on the type of seal, the assembly construction and the materials used. Material certification is in accordance with EN10204 3.1.

Additional material certification and testing can be provided on request, such as Positive Material Identification (PMI), Intergranular corrosion (IGC) testing, material certification in accordance with EN10204 3.2, NACE conformity for ISO-15156 (MR-0175) and/or ISO-17945 (MR-0103), NORSOK M-630 and many more.

-> Please note that the responsibility for material selection always rests with the user.

Flange Marking & Traceability

All flanges are marked by the forging shop with heat number, material designation, size, and rating. Badotherm adds a Badotherm reference number and the manufacturers name to the flange for traceability purposes.

Materials and origin

The seal parts are made from forged materials according to the applicable standards. The standard sourcing of flanges is of international origin. Optionally regional preference can be requested, for example materials from EU origin.

Testing

All seals are helium tested according the EN 13185 test procedure A.3 up to 10⁻⁹ mbar l/s before used on a diaphragm seal application.

-> See datasheet "Diaphragm Seal testing"

Cleanliness of the wetted parts

All parts are standard cleaned from excessive oil and grease. When additional requirements are needed, the parts can be cleaned according customer requirements and cleaning specifications.

Example performance calculation

Whether a diaphragm seal can be used for a specific measurement, depends on the size of the diaphragm. That size is restricted by the size of the diaphragm seal.

For pressure transmitters, Badotherm offers an online performance calculation tool to calculate its performance and to ensure that the diaphragm size is suitable for your measurement.

The table below presents the minimum span of the respective diaphragm sizes with standard process conditions. As rule of thumb, a TPE of max 5% is often considered acceptable, but it depends per situation.

Minimum span table

dD	AP/GP	DP
20mm	21 bar	na
23.5mm	17.5 bar	na
32mm	11 bar	1850 mbar
44mm	1575 mbar	255 mbar
57mm	415 mbar	70 mbar
72mm	155 mbar	30 mbar
81mm	110 mbar	20 mbar

Pressure transmitter; ambient temperature -10...+30°C; process temperature 100°C with BSO 22 fill fluid; 3 meter capillary; ID 1mm, DP both sides mounted with seal

See the general overview of all diaphragm sizes with several standard situations and in combination with Badotherm pressure gauges.

Tankspud

The clamp coupling is a many applied coupling within the pharmaceutical industry, especially because many of these companies have American roots. Badotherm delivers seals that match below standards

- Industry standard clamp size
- Clamp size according ISO2852



Clamped coupling ISO 2852

The clamp coupling is an often applied coupling within the hygienic industry. But they are available in many different norms and tube sizes. They all belong to other norm families. The most common norms are represented in this documentation.



DIN 32676 clamped coupling

The clamp coupling is a many applied coupling within the pharmaceutical industry, especially because many of these companies have American roots. Badotherm delivers seals that match below standards

- DIN 11866 row A or DIN 11850 row 2
- DIN 11866 row B or ISO1127 row 1
- DIN 11866 row C or ASME BPE

Varivent®

The Varivent® connection with clamp coupling is used in the Varinline® housing system. The highly flexible VARIVENT® modular system is the basis for the hygienic components of GEA Tuchenhagen. The Badotherm diaphragm seal made from original GEA parts can be assembled in the VARINLINE® that meet the requirement of being CIP/SIP-able, thus enabling cleaning and sterilization without the need for dismantling. The instruments can be cleaned and sterilized without any residue in automatic cleaning and sterilizing process cycles.

Dimensions table: SAT - Clamp ISO 2852

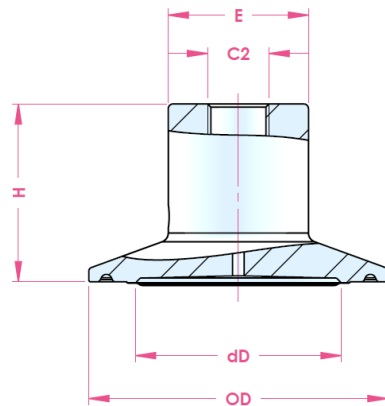

Inch	DN	Rating ¹	For pipe ²	ID pipe	C2	dD	OD	H ³	E
1"	DN25	PN40	25 x 1.2	22.6	G ½	20.0	50.5	41.0	30.0
1.25"	DN38		38 x 1.2	35.6		32.0			38.6
1.5"	DN40		40.6 x 1.2	37.6		35.0	64.0	40.6	
2"	DN51		51 x 1.2	48.6		44.0		51.6	
2,5"	DN63.5	PN25	63.5 x 1.6	60.3		57.0	77.5	38.0	64.1
3"	DN76.1		76.7 x 1.6	72.9		72.0	91.0		76.7
4"	DN101.6		101.6 x 2.0	97.6	81.0	119.0	102.5		

All dimensions in mm

Note:

- 1) for maximum pressure rating refer to the clamp specifications;
- 2) dimensions suitable for pipe per ISO 2037& BS 4825 part 1;
- 3) H sized based on G ½ instrument connection. Capillary connection H = 15mm

Dimensions table: SAT - Clamp DIN 32676

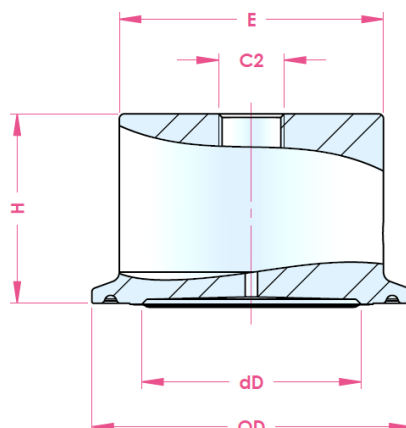

size	For pipe	rating	C2	dD	OD	E	H
25	29x26	PN40	G ½	23.5	50.5	29.0	38
40	41x38	PN40		32.0		41.0	
50	53x50	PN40		44.0	64.0	53.0	
65	70x66	PN25		52.0	91.0	70.0	
80	85x81	PN25		72.0	106.0	85.0	
100	104x100	PN25	81.0	119.0	104.0	30	

Note: for maximum pressure rating refer to the clamp specifications; dimensions suitable for pipe acc. DIN 11866 row A or DIN 11850 row 2; All dimensions in mm

size	For pipe	rating	C2	dD	OD	E	H
42.4	42.4x38.4	PN40	G ½	32.0	64.0	42.4	38
48.3	48.3x44.3	PN40		32.0		48.3	
60.3	60.3x56.3	PN40		44.0	77.5	60.3	
76.1	76.1x72.1	PN25		58.0	91.0	76.1	
88.9	88.9x84.3	PN25		72.0	106.0	88.9	

Note: for maximum pressure rating refer to the clamp specifications; dimensions suitable for pipe acc. DIN 11866 row B or ISO1127 row 1 ; All dimensions in mm

size	For pipe	rating	C2	dD	OD	E	H
1"	25.4x22.1	PN40	G ½	20.0	50.5	24.4	38.0
1.5"	38.1x34.8	PN40		23.5		38.1	
2"	50.8x47.5	PN40		44.0	64.0	50.8	
2.5"	63.5x60.2	PN40		50.0	77.5	63.5	
3"	76.2x72.9	PN25		58.0	91.0	76.2	

Note: for maximum pressure rating refer to the clamp specifications; dimensions suitable for pipe acc. DIN 11866 row C or ASME BPE; All dimensions in mm

Dimensions table: SATS – Tank spud

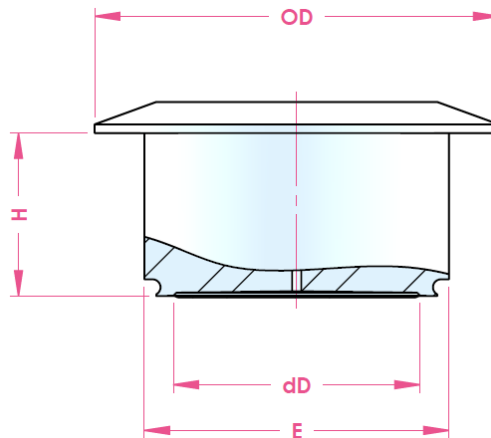

Industry Standard

Extension length	rating	dD	E	OD	H
2"	PN40	81.0	100.0	133.0	54.0
6"					152.0

All dimensions in mm

ISO 2852 clamping standard

Size	Extension length	rating	dD	E	OD	H
3" / DN 76.1	2"	PN40	57.0	72.0	91.0	52.0
	4"					102.0
4" / DN 101.6	2"	PN40	81.0	101.6	119.0	52.0
	4"					102.0

All dimensions in mm

Dimensions table: SATS – Welding process part for ISO 2852 clamping

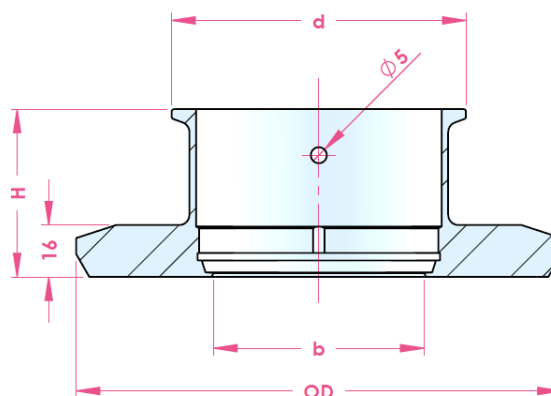

Size	Extension length	rating	d	OD	H	b
3" / DN 76.1	2"	PN40	91.0	150.0	51.8	65.0
	4"				101.8	
4" / DN 101.6	2"	PN40	119.0	200.0	51.8	93.8
	4"				101.8	

Dimensions table: SAV – Varivent®

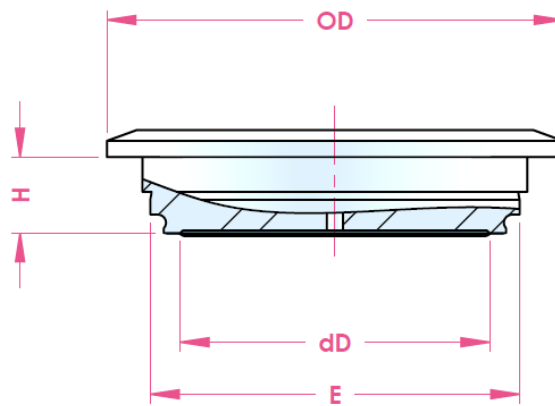

Connection	Size VARILINE®	rating	dD	E	OD	H	Clamp
Type F	DN25/ISO25 and 1"	PN40	44.0	50.0	66.0	14.0	66
Type N	DN40-DN125 / ISO32-100 and 1.5"-6"	PN40	57.0	68.0	84.0		84

All dimensions in mm

Change log

Date	Change
23-5-2022	Split Sanitary diaphragm seals datasheets in separate categories (clamped & Threaded)

Holland – Romania – India – Thailand – Dubai – USA

To our knowledge, the information contained herein is accurate as of the date of this document. However neither Badotherm, nor its affiliates makes any warranty, express or limited, or accepts any liability in connection with this information or its use. This information is for technical skilled persons at their own discretion and risk and does not relate to the use of this product in combination with any other product. The user alone finally determines suitability of any information or material in contemplated use, the manner of use and whether any patents are infringed. This information gives typical properties only. Badotherm reserves the right to make changes to the specifications any materials without prior notice. The latest version of the datasheet can be found on www.badotherm.com.

© 2015 Badotherm, all rights reserved. Trademarks and/or other products referenced herein are either trademarks or registered trademarks of Badotherm.