











DATA SHEET

**INTERCHANGEABLE
PROBES AND MODULES
for class 320 transmitters**



Contents

	Interchangeable modules	2
	Differential pressure modules	2
	Hygrometry / temperature probes	3
	Heated stainless steel relative humidity/temperature probe for industrial applications	3
	Flush-mount hygrometry/temperature probes dedicated to clean rooms	3
	Stainless steel hygrometry/temperature probes	3
	Polycarbonate hygrometry/temperature probes	4
	Temperature probes	5
	Air velocity and temperature probes	6
	IAQ probes	7
	CO ₂ probe	7
	CO probe	7
	VOC probe	8
	Relay module	8
	Wireless communication module	8
	Probe cables	9

Interchangeable modules



Differential pressure modules

Differential pressure module for Si-C320 transmitters. High accuracy. With solenoid valve. For installing in already supplied transmitters. Connector for external type K thermocouple probe (probe not included, please check our available models). Supplied with tubing and 2x pressure connectors.

Superior accuracy and long-term stability and reliable measurements.

Main applications: differential pressure monitoring in clean rooms, pharma/cosmetic and semiconductors manufacturing facilities, hospital isolation rooms, operating rooms and other critical environments.

Designation: Si-PRO-DP-50. Sales reference: 27990

Designation: Si-PRO-DP-250. Sales reference: 27991

Designation: Si-PRO-DP-1000. Sales reference: 27992

Designation: Si-PRO-DP-10000. Sales reference: 27993



Parameter	Measuring range	Accuracy*	Available Resolution and Units	Tolerated overpressure
Differential pressure	Si-PRO-DP-50: -50 to 50 Pa (-0.2 to 0.2 inH ₂ O) Si-PRO-DP-250: -250 to 250 Pa (-1.0 to 1.0 inH ₂ O) Si-PRO-DP-1000: -1000 to 1000 Pa (-4.0 to 4.0 inH ₂ O) Si-PRO-DP-10000: -10,000 to 10,000 Pa (-40.0 to 40.0 inH ₂ O)	Si-PRO-DP-50: ±0.3% of measured value ±0.3 Pa (±0.3% of measured value ±0.12 inH ₂ O)*** Si-PRO-DP-250: ±0.2% of measured value ±0.8 Pa (±0.2% of measured value ± 0.0032 inH ₂ O)*** Si-PRO-DP-1000: ±0.50% of full scale*** Si-PRO-DP-10000: ±0.50% of full scale***	0.1 Pa / 1 Pa / 0.1 mmH ₂ O / 0.1 inH ₂ O / 0.01 mbar 0.01 inH ₂ O / 0.01 mmHg / 0.1 daPa / 0.001 kPa 0.01 hPa	Si-PRO-DP-50 / Si-PRO-DP-250: 25,000 Pa (100 inH ₂ O) Si-PRO-DP-1000: 20,700 Pa (83 inH ₂ O) Si-PRO-DP-10000: 86,000 Pa (345 inH ₂ O)
Air velocity**	Si-PRO-DP-50: 0 to 9 m/s (0 to 29.5 fps) Si-PRO-DP-250: 0 to 20 m/s (0 to 65.6 fps) Si-PRO-DP-1000: 0 to 40 m/s (0 to 131 fps) Si-PRO-DP-10000: 0 to 100 m/s (0 to 328 fps)	N/A	0.1 m/s	N/A
Airflow**	0 to 999,999 m ³ /h (0 to 588,577 cfm)	N/A	0.1 m ³ /h, 0.1 l/s, 0.1 m ³ /s, 1 dam ³ /h, 0.1 cfm	N/A
Air change rate**	0 to 1000 ACH	N/A	0.1 ACH, 1 ACH	N/A
K thermocouple temperature	-200 to 1300°C (-328 to 2372°F) (depending on the connected probe)	±1.1°C or ±0.4% of the measured value	0.1°C, 0.1°F	N/A

The Si-PRO-DP modules for Si-C320 transmitters have a temperature compensation from -10 to 50°C (14 to 122°F) and an auto-calibration process that ensures an excellent stability and a perfect reliability of the measurement in both low as high range over time.

Auto-calibration principle: the module's electronics manages the solenoid valve that eliminates the zero-point drift of the sensor over time. The differential pressure measurement is then independent from the environmental conditions of the sensor.

Solenoid valve lifetime: 100 million of cycles

Advantage: no zero-point drift and high accuracy

Periodicity of the auto-calibration: from 1 to 60 minutes, or deactivated. During the first ignition of the device, the self-calibration frequency is increased during 1 hour in order to provide a pressure measurement with no zero-point drift.

*All the accuracies indicated in this technical data sheet were stated in laboratory conditions, and can be guaranteed for measurements carried out in the same conditions, or carried out with calibration compensation.

** Calculated value

*** Temperature drift : 0.02% FS/K, referring to 20°C (68°F) and 50%RH



Heated stainless steel relative humidity/temperature probe for industrial applications

Interchangeable hygrometry probe for demanding relative humidity applications: 0 to 100%RH, -40 to 150°C (-40 to 302°F). Stainless steel body and sintered filter. Length 100 mm, Ø 13 mm. Supplied with adjustment certificate. This probe needs to work in combination with the Si-PRO-T-150 probe or a Pt100 probe connected to a Si-C320 transmitter using Si-ACC-ETP.



Heated probe, high accuracy and long-term stability and resistant against pollution.

Main applications: industrial processes, air handling units, drying processes, pharma production machines.

Designation: Si-PRO-U-I-100-H

Sales reference: 27986

Please refer to the Si-PRO-U-I-100-H probe specific data sheet for further details.

Flush-mount hygrometry/temperature probes dedicated to clean rooms

Interchangeable flush-mount hygrometry probe for cleanrooms: 0 to 100%RH, -20 to 80°C (-4 to 176°F). Stainless steel body and sintered filter. Autolock connector. Si-ACC-RVP cable is needed to connect to Si-CPE 320 transmitter. Supplied with adjustment certificate. **Specifically designed to be installed inside clean rooms and other regulated environments where an accurate regulation or monitoring of the humidity is required. This probe works with the Si-CPE320 transmitters. It is resistant against VHP.**



Designation: Si-PRO-U-W

Sales reference: 27987

Please refer to the Si-PRO-U-W probe specific data sheet for further details.

Stainless steel hygrometry/temperature probes

Interchangeable hygrometry probe. Stainless steel body with stainless steel filter. Length 150 mm or 300 mm, Ø 13 mm. Autolocking connector. Probe cable for class 320 transmitters is needed. Supplied with adjustment certificate.

High accuracy and long-term stability and reliable measurements.

Main applications: regulation of humidity or psychrometric values in VAC systems or in air handling units, measurement of humidity and temperature for IAQ monitoring.

Designation: Si-PRO-U-I-150. Sales reference: 27984 (probe length: 150 mm)

Designation: Si-PRO-U-I-300. Sales reference: 27985 (probe length: 300 mm)

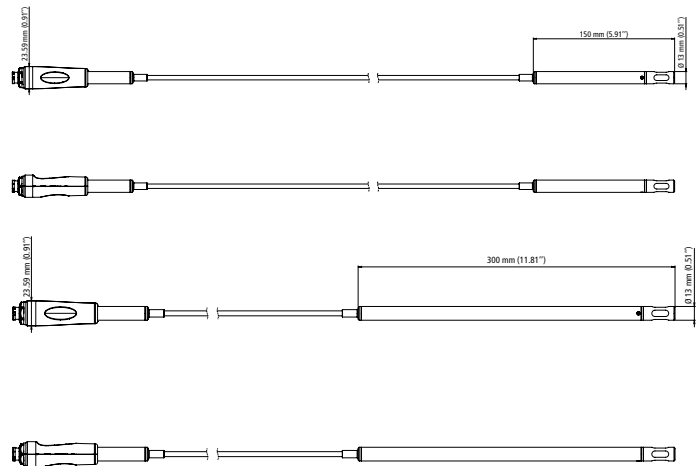

Parameter	Measuring range	Accuracy*	Resolution
Pt100 temperature (°C, °F)	-40 to 150°C (-40 to 302°F)	±0.25°C ±0.2% of measured value (±0.45°F ±0.2% measured value)	0.1°C (0.1°F)
Relative humidity (%RH)	0 to 100%RH	±1.5%RH (from 15°C to 25°C and from 5 to 95 %RH) Temperature dependence: ±0.04 x (T-20)%RH (if T<15°C or T>25°C)	0.1%RH
Wet-bulb temperature** (°C _{tw} , °F _{tw})	-50 to 100°C _{tw} (-58 to 212 °F _{tw})	-	0.1°C _{tw} (0.1°F _{tw})
Dewpoint** (°C _{td} , °F _{td})	-50 to 100°C _{td} (-58 to 212°F _{td})	-	0.1°C _{td} (0.1°F _{td})
Frost point** (°C _{tf} , °F _{tf})	-50 to 100°C _{tf} (-58 to 212 °F _{tf})	-	0.1°C _{tf} (0.1°F _{tf})
Absolute humidity** (g/m ³)	0 to 1000 g/m ³	-	0.1 g/m ³
Enthalpy** (kJ/kg)	0 to 15,000 kJ/kg	-	0 to 9999.9: 0.1 kJ/kg 10,000 to 15,000: 1 kJ/kg
Mixing ratio** (g/kg)	0 to 1000 g/kg	-	0.1 g/kg

Polycarbonate hygrometry/temperature probes

Interchangeable hygrometry/temperature probe. Plastic body with stainless steel filter. Length 150 mm, Ø 13 mm. Autolocking connector. Probe cable for connection to class 320 transmitters is needed. Supplied with adjustment certificate.

High accuracy and long-term stability and reliable measurements.

Main applications: regulation of humidity or psychrometric values in VAC systems or in air handling units.

Designation: Si-PRO-U-150

Sales reference: 27983

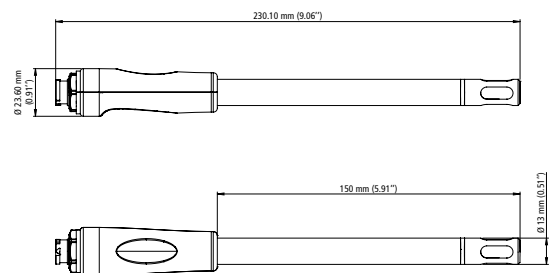

Parameter	Measuring range	Accuracy*	Resolution
Pt100 temperature (°C, °F)	-40 to 80°C (-40 to 176°F)	±0.25°C ±0.2% of measured value (±0.45°F ±0.2% measured value)	0.1°C (0.1°F)
Relative humidity (%RH)	0 to 100%RH	±1.5 %RH (from 15°C to 25°C and from 5 to 95 %RH) Temperature dependence: ±0.04 x (T-20)%RH (if T<15°C or T>25°C)	0.1%RH
Wet-bulb temperature** (°C _{tw} , °F _{tw})	-50 to 100°C _{tw} (-58 to 212°F _{tw})	-	0.1°C _{tw} (0.1°F _{tw})
Dewpoint** (°C _{td} , °F _{td})	-50 to 100°C _{td} (-58 to 212°F _{td})	-	0.1°C _{td} (0.1°F _{td})
Frost point** (°C _{tf} , °F _{tf})	-50 to 100°C _{tf} (-58 to 212 °F _{tf})	-	0.1°C _{tf} (0.1°F _{tf})
Absolute humidity** (g/m ³)	0 to 1000 g/m ³	-	0.1 g/m ³
Enthalpy** (kJ/kg)	0 to 15,000 kJ/kg	-	0 to 9999.9: 0.1 kJ/kg 10,000 to 15,000: 1 kJ/kg
Mixing ratio** (g/kg)	0 to 1000 g/kg	-	0.1 g/kg

*All the accuracies indicated in this technical datasheet were stated in laboratory conditions, and can be guaranteed for measurements carried out in the same conditions, or carried out with calibration compensation.
**Calculated value

Temperature probes



Interchangeable temperature probe. Stainless steel sheath, dimensions: length 153 mm, Ø 6 mm. Autolock connector. Supplied with adjustment certificate.

High accuracy and long-term stability and reliable measurements.

Main applications: VAC ductworks, Air Handling Units and IAQ.

Designation: Si-PRO-T-150

Sales reference: 27988

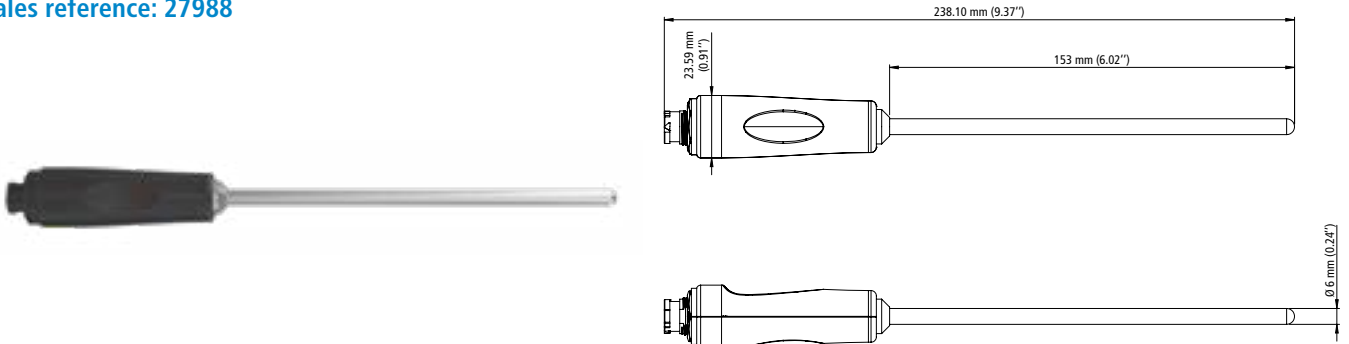

Measuring range	-80 to 150°C (-112 to 302°F)
Accuracy*	±0.25°C ±0.2% of measured value (±0.45°F ±0.2% measured value)
Resolution	0.1°C (0.1°F)

Adaptor for connecting any 3-wire Pt100 probe into the Si-C320 or the Si-CPE320 transmitters. Automatic locking connector.

Designation: Si-ACC-ETP

Sales reference: 28004

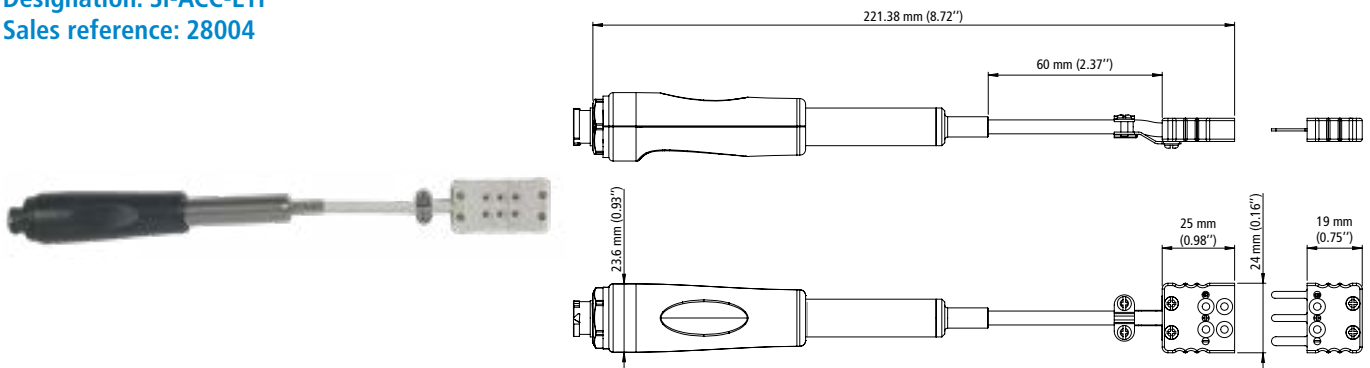

Measuring range	According to the connected probe (maximum measuring range in temperature: -100 to 400°C / -148 to 752°F)
Accuracy*	Depending on the connected probe
Resolution	0.1°C (0.1°F)

*All the accuracies indicated in this technical datasheet were stated in laboratory conditions, and can be guaranteed for measurements carried out in the same conditions, or carried out with calibration compensation.

Air velocity and temperature probes



Interchangeable hotwire probe for air velocity and temperature measurements. Stainless steel body length 267 mm, Ø 8 mm. Autolock connector. Supplied with adjustment certificate.

High accuracy and long-term stability, reliable measurements. Thanks to its design, it minimises the impact of the angle of the airflow on the measurements.

Main applications: laminar flow monitoring in clean rooms, isolators, glove boxes, fume hoods, isolation cabinets, pharmaceutical/cosmetic and semiconductors manufacturing facilities.

Designation: Si-PRO-V-300

Sales reference: 27989

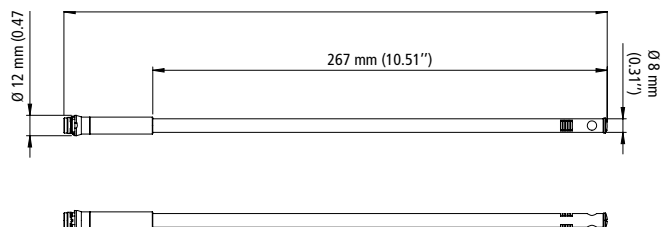

Parameter	Measuring range	Accuracy*	Resolution
Air velocity	0 to 30 m/s (0 to 98.4 fps)	0 to 3.0 m/s: $\pm 3\%$ of measured value ± 0.03 m/s (0 to 9.84 fps: ± 0.98 fps $\pm 3\%$ of measured value) 3.1 to 30.0 m/s: $\pm 3\%$ of measured value ± 0.1 m/s (10.2 to 98.4 fps: ± 0.33 fps $\pm 3\%$ of measured value)	0 to 30 m/s: 0.01 m/s (0 to 98.4 fps: 0.1 fps)
Temperature	0 to 50°C (32 to 122°F)	$\pm 0.3\%$ of reading $\pm 0.25^\circ\text{C}$ ($\pm 0.45^\circ\text{F}$ $\pm 0.3\%$ of measured value)	0.1°C (0.1°F)
Airflow**	0 to 999,999 m ³ /h (0 to 588,577 cfm)	$\pm 3\%$ of reading or ± 0.03 x sheath section (cm ²)	0.1 m ³ /h, 0.1 l/s, 0.1 m ³ /s, 1 dam ³ /h, 0.1 cfm
Air change rate**	0 to 1000 ACH	-	0.1 ACH, 1 ACH

*All the accuracies indicated in this technical datasheet were stated in laboratory conditions, and can be guaranteed for measurements carried out in the same conditions, or carried out with calibration compensation.

**Calculated value

IAQ probes



CO₂ probe

Interchangeable CO₂ probe. Plastic body, Ø 29.5 mm, length: 175 mm. Autolock connector. Probe cable connection to class 320 transmitters is needed.. Supplied with mounting flange and adjustment certificate.

High accuracy and long-term stability, reliable measurements.

Main applications: CO₂ monitoring (IAQ) in VAC systems of office buildings, commercial buildings, education facilities.

Designation: Si-PRO-CO₂

Sales reference: 27995

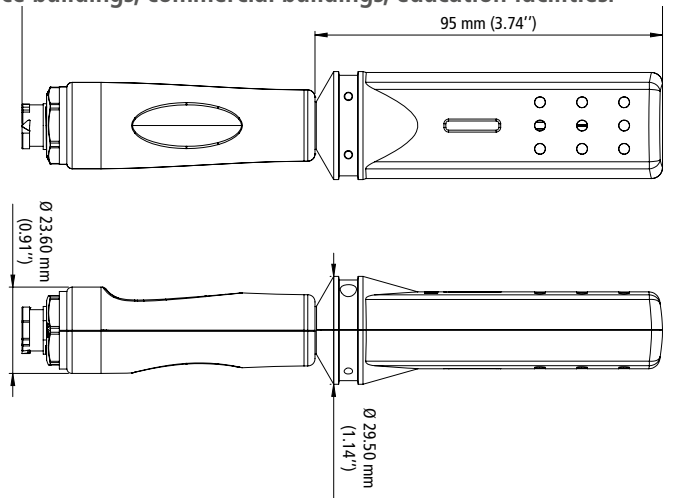

Measuring range	0 to 10,000 ppm
Accuracy*	From 0 to 5000 ppm: $\pm 50 \text{ ppm} \pm 3\%$ of measured value > 5000 ppm: $\pm 50 \text{ ppm} \pm 5\%$ of measured value Temperature drift: 4 ppm/K, referring to 20°C (68°F) and 50%RH
Resolution	0.1 ppm
Operating temperature	-10 to 50°C (14 to 122°F)

CO probe



Interchangeable CO probe. Plastic body, Ø 29.5 mm, length: 175 mm. Autolock connector. Probe cable for connection to class 320 transmitters is needed. Supplied with mounting flange and adjustment certificate.

High accuracy and long-term stability, reliable measurements.

Main applications: CO monitoring in parking lots, boiler rooms and in industrial environments.

Designation: Si-PRO-CO

Sales reference: 27994

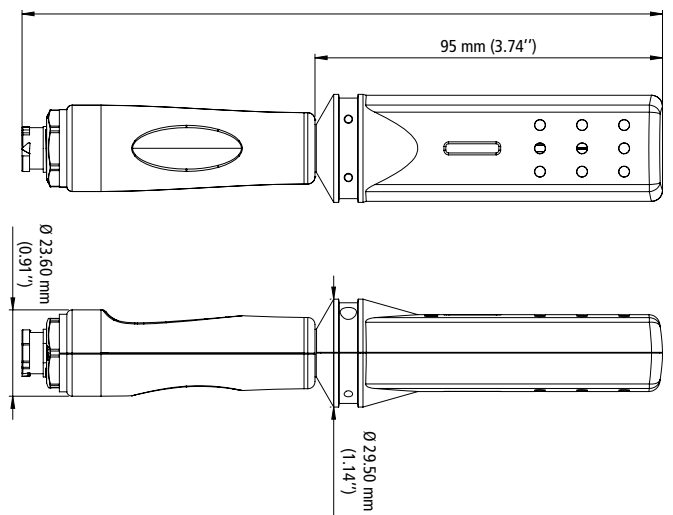

Measuring range	0 to 500 ppm
Accuracy*	$\pm 3 \text{ ppm}$ or $\pm 3\%$ of measured value at 20°C (68°F) Temperature drift: 0.5 ppm/K, referring to 20°C (68°F) and 50%RH
Resolution	0.1 ppm
Operating temperature	-10 to 50°C (14 to 122°F)

*All the accuracies indicated in this technical datasheet were stated in laboratory conditions, and can be guaranteed for measurements carried out in the same conditions, or carried out with calibration compensation.

VOC probe

Interchangeable VOC probe. Plastic body, Ø 29.5 mm, length: 175 mm. Autolock connector. Probe cable for connection to class 320 transmitters is needed. Supplied with mounting flange and adjustment certificate.



High accuracy and long-term stability, reliable measurements.

Main applications: VOC monitoring (IAQ) in VAC systems of office buildings, commercial buildings, education facilities, Control of TVOC in pharmaceutical industries.

Designation: Si-PRO-VOC

Sales reference: 27996

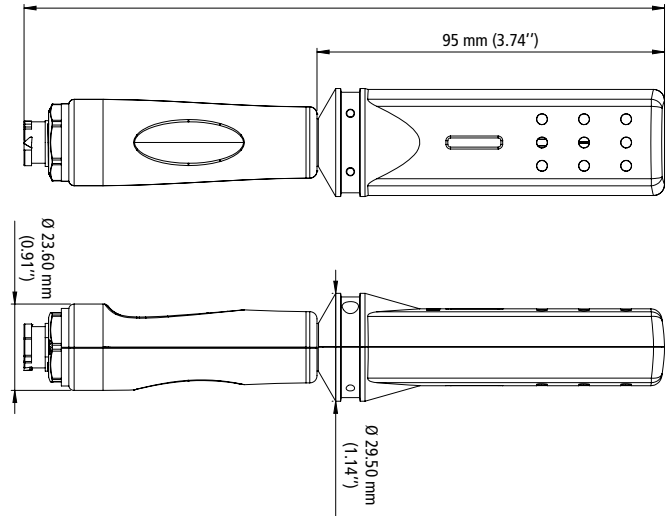

Measuring range	Isobutene equivalent: 0 to 1000 ppb CO ₂ equivalent: 400 to 2000 ppm
Resolution	TVOC: 1 ppb CO ₂ eq: 1 ppm
Operating temperature	-10 to 50°C (14 to 122°F)
Switchoff time	ppb (TVOC): immediate readings for event detection ppm (CO ₂ equivalent): a warm-up time of 15 minutes is needed

Relay module

4x relay module for Si-C320 transmitters. SPDT relays 40 V_{DC} / 600 mA. For installation in already delivered Si-C320 transmitters.

Designation: Si-M4R

Sales reference: 27997



Wireless communication module

Wireless module for the configuration of Si-C320 and Si-CPE320 transmitters using the iOS/Android mobile app. For installation in already delivered Si-C320 and Si-CPE320 transmitters.

Designation: Si-ACC-WLM

Sales reference: 28007



*All the accuracies indicated in this technical datasheet were stated in laboratory conditions, and can be guaranteed for measurements carried out in the same conditions, or carried out with calibration compensation.

Probe cables

A probe cable is mandatory to connect the probe to a class 320 transmitter according to your probe. 2 different cables are available (see table below):

- **Si-ACC-R2; Sales reference: 27999**
- **Si-ACC-RVP; Sales reference: 28002**

2 extension cable are also available:

- **5 m length: Si-ACC-R5; Sales reference: 28000**
- **10 m length: Si-ACC-R10; Sales reference: 28001**

It is possible to combine probe cables, up to a maximum total length of 12 m.
Please see below the compatibility table for each probe cable:

Probes	Connection cable between the transmitter and the probe		Extensions	
	Si-ACC-R2	Si-ACC-RVP	Si-ACC-R5	Si-ACC-R10
Si-PRO-U-150	✓	N/A	✓	✓
Si-PRO-U-I-150	✓	N/A	✓	✓
Si-PRO-U-I-300	✓	N/A	✓	✓
Si-PRO-U-I-100-H	✓	N/A	✓	✓
Si-PRO-U-W	N/A	✓	✓	✓
Si-PRO-T-150	✓	N/A	✓	✓
Si-ACC-ETP	✓	N/A	✓	✓
Si-PRO-V-300	N/A	✓	✓	✓
Si-PRO-CO	✓	N/A	✓	✓
Si-PRO-CO2	✓	N/A	✓	✓
Si-PRO-VOC	✓	N/A	✓	✓