

Honeywell BW™ Ultra

Portable Multi-Gas Detector

At Honeywell, we always put your safety where it should be – first. With Honeywell BW™ Ultra, our new portable five-gas detector, you will be able to do the same for your workers. Designed specifically for sampling and monitoring confined spaces, before and after entry, Honeywell BW™ Ultra has enhanced sensor technology, visibility on gas readings, comfort, and connectivity. This makes it the most reliable and user-friendly way to prevent a safety incident.



GENERAL SPECIFICATIONS

SIZE	5.8 x 3.3 x 1.6 in. / 14.8 x 8.5 x 4.0 cm
WEIGHT	14.5 oz. / 411 g (with clip)
OPERATING TEMPERATURE	-4 to +131° F / -20 to +50° C
INGRESS PROTECTION	IP66/68
WARRANTY	Instrument: 3 years Sensors: 3 years (2 years NH ₃ , 1 year PID and Cl ₂) Battery: 2 years

ORDERING INFORMATION

Honeywell BW™ Ultra Five-Gas Detector with Pump	Black Housing	Yellow Housing
Honeywell BW™ Ultra 5-gas detector (O ₂ , LEL, H ₂ S, CO, VOCs)	HU-X1W1H1M1Q1-B-N	HU-X1W1H1M1Q1-Y-N
Honeywell BW™ Ultra 5-gas detector (O ₂ , LEL, H ₂ S, CO, CO ₂ IR)	HU-X1W1H1M1B1-B-N	HU-X1W1H1M1B1-Y-N
Honeywell BW™ Ultra 5-gas detector (O ₂ , LEL, H ₂ S, CO, SO ₂)	HU-X1W1H1M1S1-B-N	HU-X1W1H1M1S1-Y-N
Honeywell BW™ Ultra 5-gas detector (O ₂ , LEL, H ₂ S, CO, NH ₃)	HU-X1W1H1M1A1-B-N	HU-X1W1H1M1A1-Y-N
Honeywell BW™ Ultra 5-gas detector (O ₂ , LEL, H ₂ S, CO, Cl ₂)	HU-X1W1H1M1C1-B-N	HU-X1W1H1M1C1-Y-N
Honeywell BW™ Ultra Four-Gas Detector with Pump	Black Housing	Yellow Housing
Honeywell BW™ Ultra 4-gas detector (O ₂ , LEL, H ₂ S, CO)	HU-X1W1H1M100-B-N	HU-X1W1H1M100-Y-N

Note: Listed above are commonly ordered instrument configurations. To create a custom Honeywell BW™ Ultra detector, use the configurator table on the next page or contact Honeywell Analytics.

Honeywell BW™ Ultra Portable Multi-Gas Detector

Honeywell BW™ Ultra Order Number Configurator

▶ Sensor 4 - Toxic 2		▶ Sensor 5 - Toxic 3	
None (dummy sensor)	00	00	None (dummy sensor)
H ₂ S (hydrogen sulfide)	H1	Q1	PID for VOCs (volatile organic compounds)
CO (carbon monoxide)	M1	W4	IR (infrared) for %LEL + % vol. (combustibles)
▶ Sensor 3 - Toxic 1		B1	IR (infrared) for CO ₂ (carbon dioxide)
None (dummy sensor)	00	S1	SO ₂ (sulfur dioxide)
H ₂ S (hydrogen sulfide)	H1	A1	NH ₃ (ammonia)
CO (carbon monoxide)	M1	R1	H ₂ (hydrogen)
▶ Sensor 2 - Combustible Gases		C1	Cl ₂ (chlorine)
None (dummy sensor)	00	D1	NO ₂ (nitrogen dioxide)
%LEL (combustibles), filtered	W1	Z1	HCN (hydrogen cyanide)
%LEL (combustibles), unfiltered	W2	N1	NO (nitrogen monoxide)
%LEL (combustibles), carbon filtered for mining*	W3	M2	CO (carbon monoxide), H ₂ (hydrogen) resistant
▶ Sensor 1 - Oxygen		▶ Housing	
None	00	B	Black housing
O ₂ (oxygen)	X1	Y	Yellow housing
▶ Base Unit		▶ Region	
Base unit	HU	N	North America
		E	Europe
		U	United Kingdom
		C	China/New Zealand
		A	Australia
		B	Brazil
		R	Russia
		X	Other region with 3-pin UK plug
		Y	Other region with 2-pin EU plug
		M	Mining

Order number: HU - - - - - - -

For example, the order number for a Honeywell BW™ Ultra configured for O₂, %LEL (filtered), H₂S, CO, and SO₂ and equipped with a black housing and North American power connectivity would be HU-X1W1H1M1S1-B-N.

Honeywell BW™ Ultra Portable Multi-Gas Detector

ORDERING INFORMATION (CONTINUED)

Confined Space Kits	Order Number
Honeywell BW™ Ultra Deluxe Confined Space Kit	HU-CK-DL
Carrying case for Honeywell BW™ Ultra with foam and lid insert	HU-CK-CC

Carrying & Protective Accessories	Order Number
Concussion-proof boot	HU-BOOT
Impact screen protector	HU-ISP
LCD scratch protector (kit of 5)	HU-PG5
LCD scratch protector (kit of 50)	HU-PG50
Neck strap with safety release	GA-NS-1
Short strap (6 in. / 15.2 cm)	GA-LY-1
Extension strap (4 ft. / 1.2 m)	GA-ES-1
Chest harness	GA-CH-2

Sampling Equipment	Order Number
Sampling hose (10 ft. / 3 m, 1/8 in. I.D., 1/4 in. O.D.) kit	HOSE1-10
Sampling hose (20 ft. / 6.1 m, 1/8 in. I.D., 1/4 in. O.D.) kit	HOSE1-20
Sampling hose (65 ft. / 19.8 m, 1/8 in. I.D., 1/4 in. O.D.) kit	HOSE1-65
Sampling hose (75 ft. / 22.8 m, 1/8 in. I.D., 1/4 in. O.D.) kit	HOSE1-75
Sampling hose (10 ft. / 3 m, 1/8 in. I.D., 1/4 in. O.D.) kit, Teflon lined for reactive gases	HOSE2-10
Sampling hose (20 ft. / 6.1 m, 1/8 in. I.D., 1/4 in. O.D.) kit, Teflon lined for reactive gases	HOSE2-20
Sampling hose (65 ft. / 19.8 m, 1/8 in. I.D., 1/4 in. O.D.) kit, Teflon lined for reactive gases	HOSE2-65
Sampling hose (75 ft. / 22.8 m, 1/8 in. I.D., 1/4 in. O.D.) kit, Teflon lined for reactive gases	HOSE2-75
Sample probe with hydrophobic and particulate filters	GA-PROB1-1
Replacement filter and gasket kit for one for sample probe (GA-PROB1-1)	GA-PROB-FIL-K1
Replacement particulate filter for GA-PROB1-1 (kit of 25)	GA-PROB-PFIL-K25
Replacement syringe filter for sample probe (GA-PROB1-1)	GA-SFIL
Replacement syringe filters (kit of 20) for sample probe (GA-PROB1-1)	GA-SFIL-K1
Metallic sintered particulate filter	GA-MFILTER
Sampling float	GA-FLOAT
Replacement hydrophobic filter with male connector	D4-WT-1
Water trap with barbed connectors	WT-2

Power Accessories	Order Number
Multi-unit cradle charger	HU-C01-MC5
Rechargeable battery pack with screw	HU-BAT

Honeywell IntelliDoX® Automated Instrument Management System	Order Number
Honeywell IntelliDoX® docking station for Honeywell BW™ Ultra	DX-ULTRA
Honeywell IntelliDoX® Nest for Honeywell BW™ Ultra	DX-NEST-ULTRA
Honeywell IntelliDoX® enabler kit, NA version (North America) <i>Includes power supply with region-specific AC power cord, ethernet cable, inlet (purge) filter assembly, 3 ft. / 1 m calibration gas tubing, 3 ft. / 1 m purge gas tubing, 15 ft. / 4.5 m exhaust tubing and quick connect fittings.</i>	DX-ENBL-NA

Note: One Honeywell IntelliDoX® enabler kit is required for each docking system. Each docking system can support up to 5 Honeywell IntelliDoX® modules.

Honeywell BW™ Ultra Portable Multi-Gas Detector

ORDERING INFORMATION (CONTINUED)	
Testing Equipment	Order Number
Quad-gas: CH ₄ (2.5%), O ₂ (18.0%), H ₂ S (25 ppm), CO (100 ppm), 34 L, balance N ₂ (requires REG-DF-1 or REG-0.5)	CG-Q34-4
Quad-gas: CH ₄ (2.5%), O ₂ (18.0%), H ₂ S (25 ppm), CO (100 ppm), 58 L, balance N ₂ (requires REG-DF-1 or REG-0.5)	CG-Q58-4
Demand flow regulator (for use with MicroDock II or IntelliDoX)	REG-DF-1
Calibration gas regulator (0.5 LPM)	REG-0.5
Calibration hose, Tygon (1 ft. / 0.3 m, 1/8 in. I.D., 1/4 in. O.D.)	C2-HOSE1-1
Wall mount (adjustable) for 34, 58, 103 L gas cylinders, red	MK-CG2-58
Replacement Sensors	Order Number
One-series dummy sensor	SR-DUMM-1S
4R+ dummy sensor	SR-DUMM-4R
Replacement oxygen (O ₂) sensor (one-series)	SR-X1-1S
Replacement combustible (LEL) sensor (filtered, one-series)	SR-W1-1S
Replacement combustible (LEL) sensor (unfiltered, one-series)	SR-W2-1S
Replacement combustible (LEL) sensor (carbon filtered for mining, one-series)	SR-W3-1S
Replacement hydrogen sulfide (H ₂ S) sensor (one-series)	SR-H1-1S
Replacement carbon monoxide (CO) sensor (one-series)	SR-M1-1S
Replacement volatile organic compounds (VOC) PID sensor (4R+)	SR-Q1-4R
Replacement combustible (LEL) IR sensor (4R+)	SR-W4-4R
Replacement carbon dioxide (CO ₂) IR sensor (4R+)	SR-B1-4R
Replacement sulfur dioxide (SO ₂) sensor (4R+)	SR-S1-4R
Replacement ammonia (NH ₃) sensor (4R+)	SR-A1-4R
Replacement hydrogen (H ₂) sensor (4R+)	SR-R1-4R
Replacement chlorine (Cl ₂) sensor (4R+)	SR-C1-4R
Replacement nitrogen dioxide (NO ₂) sensor (4R+)	SR-D1-4R
Replacement hydrogen cyanide (HCN) sensor (4R+)	SR-Z1-4R
Replacement nitrogen monoxide (NO) sensor (4R+)	SR-N1-4R
Replacement carbon monoxide (CO) sensor, hydrogen (H ₂) resistant (4R+)	SR-M2-4R
Sensor conditioning station for 4R+ sensors	T03-0001-000
PID 4R+ sensor top cover removal tool (kit of 3)	G02-0306-003
PID sensor lamp cleaning kit	081-0017-000
Spares & Replacement Parts	Order Number
Pump inlet connector	HU-INCONN
Replacement inlet filter kit (kit of 10)	HU-IN-FIL
Replacement exhaust filter kit (kit of 10)	HU-EX-FIL
Replacement auxiliary pump filter (kit of 5)	M5-AF-K2
Replacement auxiliary pump filter (kit of 100)	M5-AF-K2-100

Honeywell BW™ Ultra Portable Multi-Gas Detector

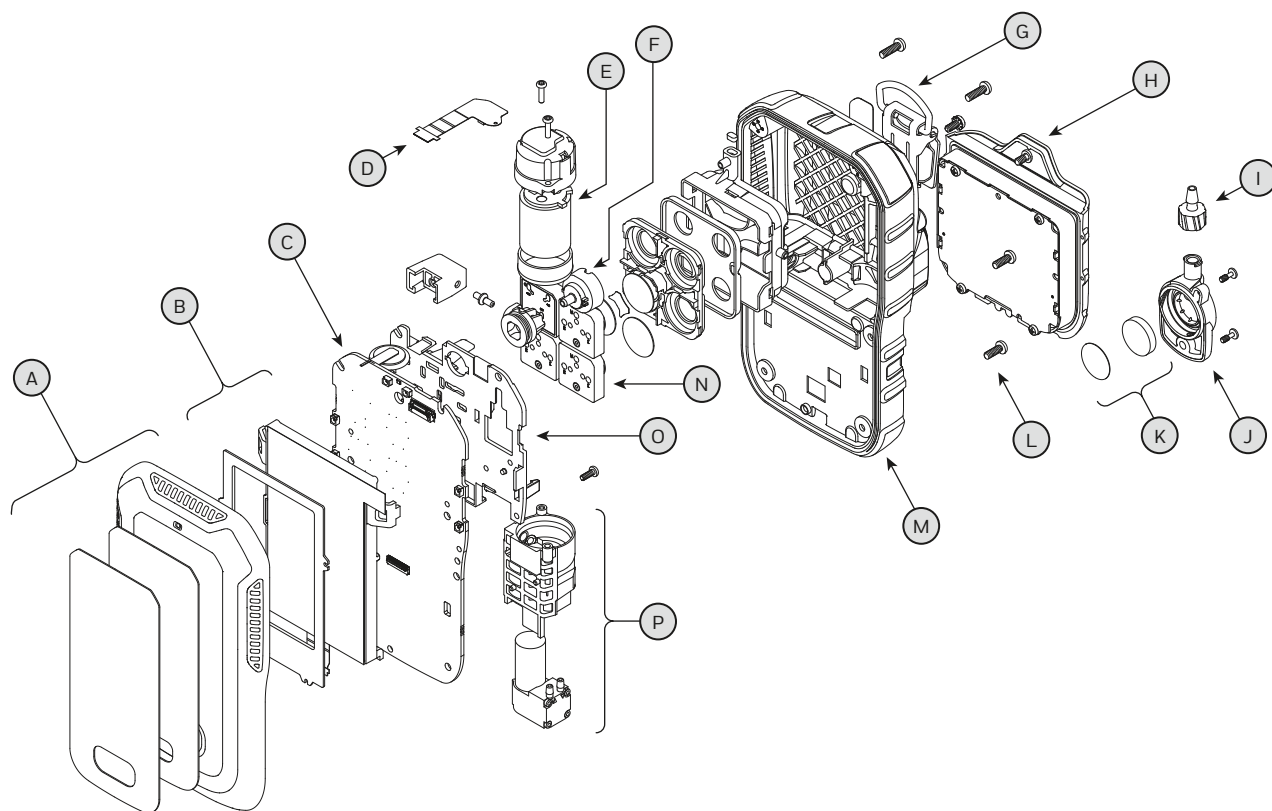

Legend	Service Parts	Order Number
A	Replacement front enclosure with LCD gasket (black)	HU-FC-B
A	Replacement front enclosure with LCD gasket (yellow)	HU-FC-Y
B	Replacement LCD kit (includes LCD, LCD holder, and flex connector)	HU-LCD
C	Replacement PCB assembly	HU-PCB
D	Replacement flex PCB	HU-FPCB
E	Replacement Toxic 3 (4R) sensor, see page 4	
F	Replacement exhaust filter kit (kit of 10)	HU-EX-FIL
G	Replacement alligator clip with screw	HU-AG
H	Replacement rechargeable battery pack with screw	HU-BAT
I	Replacement pump inlet connector	HU-INCONN
J	Replacement pump inlet with screw	HU-IN
K	Replacement inlet filter kit (kit of 10)	HU-IN-FIL
L	Replacement screw kit for 5 detectors	HU-SCREW
M	Replacement back enclosure	HU-BC
N	Replacement sensors, see page 4	
O	Replacement manifold kit (includes one-series sensor manifold and exhaust manifold assemblies)	HU-MAN
P	Replacement pump (includes pump and 4R+ manifold)	HU-PUMP
	Replacement vibration motor	GA-VM-2

Note: Please refer to the instrument's documentation (shipped with the product or available at www.honeywellanalytics.com) for complete instructions on common service procedures. Improper servicing or maintenance may affect warranty eligibility. Honeywell assumes no liability for damages resulting from improper servicing or maintenance.

For more information

www.honeywellanalytics.com