

DIAL CASE STYLES

2.5" "B" & 2.5" "F" STYLE DIAL CASE

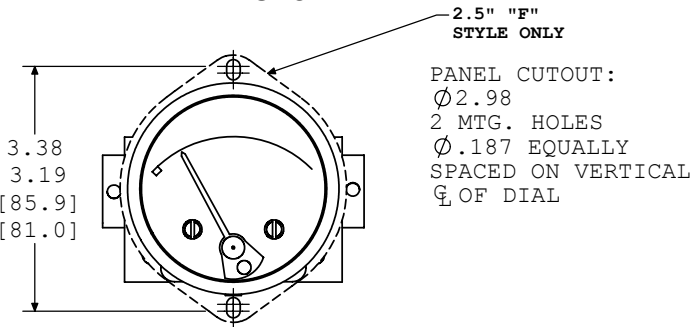

*.78 FOR "F"-STYLE GA. CASE
[19.8]

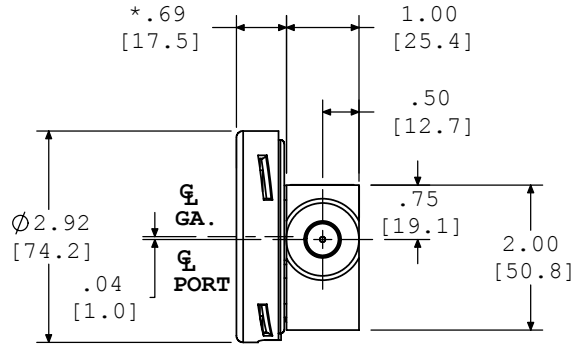

"B"-STYLE DIAL CASE

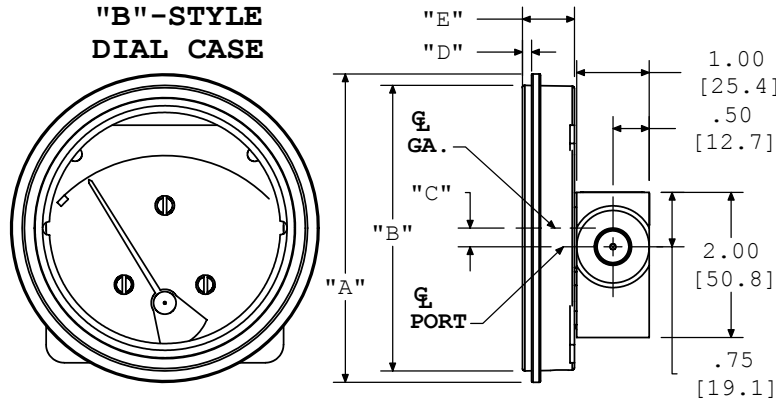

DIAL CASE SIZES & DIMENSIONS

	3.5"	4.5"	6.0"
A	4.25[108.0]	5.25[133.4]	6.68[169.7]
B	3.94[100.1]	4.94[125.5]	6.44[163.6]
C	.25[6.4]	.62[15.7]	1.35[34.3]
D	.13[3.3]	.13[3.3]	.13[3.3]
E	.72[18.3]	.72[18.3]	.75[19.1]

"F"-STYLE DIAL CASE

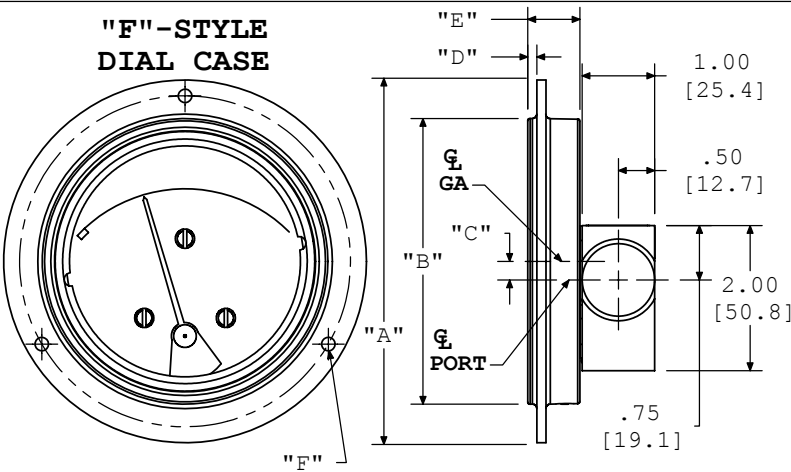

DIAL CASE SIZES & DIMENSIONS

	3.5"	4.5"	6.0"
A	5.00[127.0]	6.00[152.4]	7.62[193.5]
B	3.94[100.1]	4.94[125.5]	6.44[163.6]
C	.25[6.4]	.62[15.7]	1.35[34.3]
D	.13[3.3]	.13[3.3]	.13[3.3]
E	.72[18.3]	.72[18.3]	.75[19.1]
F	PANEL CUTOUT: ϕ 4.00 3 MTG. HOLES ϕ .187 EQUALLY SPACED ON A ϕ 4.56 B.C.	PANEL CUTOUT: ϕ 5.00 3 MTG. HOLES ϕ .218 EQUALLY SPACED ON A ϕ 5.38 B.C.	PANEL CUTOUT: ϕ 6.50 3 MTG. HOLES ϕ .218 EQUALLY SPACED ON A ϕ 7.00 B.C.

PORTING LOCATIONS

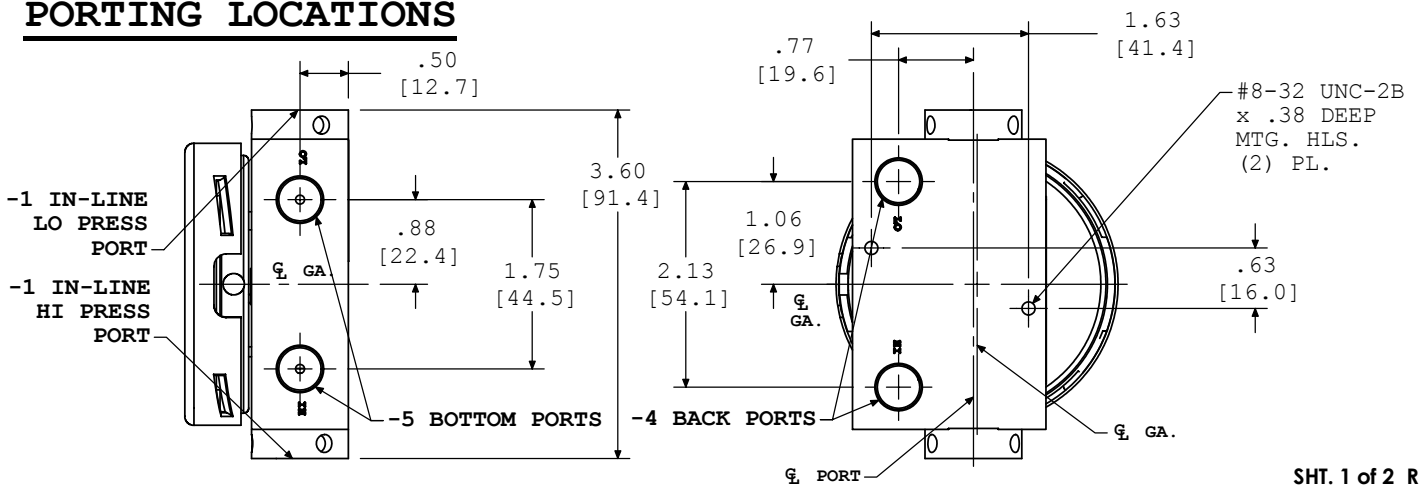

MODEL 1201PGS-1 (1/4" NPT) 1 SWITCH CONFIGURATION

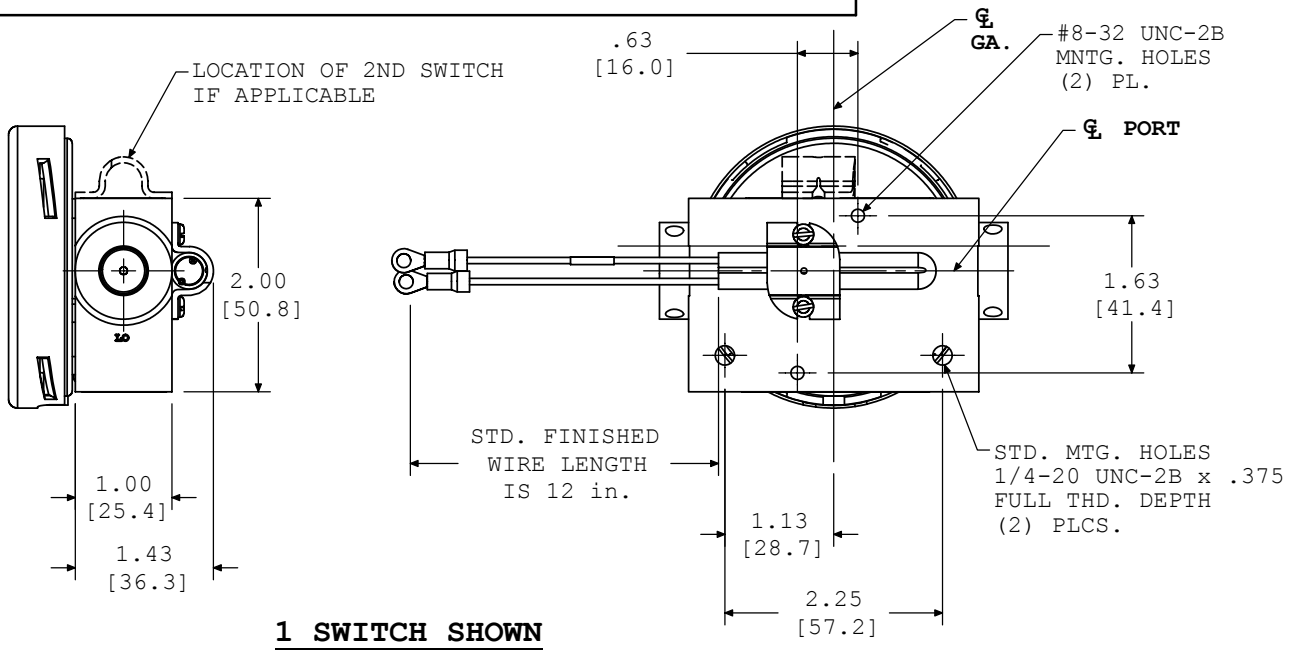

MODEL 1201PS (1/4" NPT) 1 SWITCH CONFIGURATION

