

REED

Model R5010 TRMS Digital Multimeter



Instruction Manual

www.reedinstruments.com

Table of Contents

Safety	3-4
<i>IEC1010 Overvoltage Installation Category</i>	3
<i>Warnings</i>	4
Features.....	5
Specifications.....	5-8
Instrument Description	9
Display Description	10
Operating Instructions.....	11-18
<i>DC Voltage Measurement</i>	11
<i>AC Voltage Measurement</i>	11
<i>DC Current Measurement</i>	12
<i>AC Current Measurement</i>	13
<i>Resistance Measurement</i>	14
<i>Continuity Check</i>	14
<i>Diode Test</i>	14
<i>Temperature Measurement</i>	15
<i>Capacitance Measurement</i>	15
<i>Frequency Measurement</i>	15
<i>%4-20mA Measurement</i>	16
<i>Autoranging/Manual Range</i>	16
<i>Max/Min</i>	16
<i>Relative Mode</i>	17
<i>Display Backlight</i>	17
<i>Hold</i>	17
<i>Peak Hold</i>	17
<i>Low Battery Indication</i>	18
<i>Auto Power Off</i>	18
Maintenance.....	18
Battery Replacement.....	19
Replacing the Fuses.....	20

Safety



This symbol adjacent to another symbol, terminal or operating device indicates that the operator must refer to an explanation in the Instruction Manual to avoid personal injury or damage to the meter.

WARNING

Indicates a potentially hazardous situation, which if not avoided, could result in death or serious injury.

CAUTION

Indicates a potentially hazardous situation, which if not avoided, may result damage to the product.



The terminal(s) so marked must not be connected to a circuit point for which the voltage with respect to ground exceeds (in this case) 1000 VAC or VDC.



This symbol adjacent to one or more terminals identifies them as being associated with ranges that may, in normal use, be subject to particularly hazardous voltages. For maximum safety, the meter and its test leads should not be handled when these terminals are energized.



Indicates that a instrument is protected throughout by double insulation or reinforced insulation.

IEC1010 Overvoltage Installation Category

Overvoltage Category I is equipment for connection to circuits for which measures are taken. Examples include protected electronic circuits.

Overvoltage Category II is energy-consuming equipment to be supplied from the fixed installation. Examples include household, office, and laboratory appliances.

Overvoltage Category III is equipment in fixed installations. Examples include switches in the fixed installation and some equipment for industrial use with permanent connection to the fixed installation.

Overvoltage Category IV is for use at the origin of the installation. Examples include electricity meters and primary over-current protection equipment.

Warnings

This meter has been designed for safe use, but must be operated with caution. The warnings listed below must be carefully followed for safe operation.

1. **NEVER** apply voltage or current to the meter that exceeds the specified maximum Input Protection Limits:

Function	Maximum Input
V DC or V AC	1000VDC/AC RMS
mA AC/DC	500mA 1000V fast acting fuse
A AC/DC	10A 1000V fast acting fuse (20A for 30 seconds max every 15 minutes)
Frequency, Resistance, Capacitance, Duty Cycle, Diode Test, Continuity	1000VDC/AC RMS
Temperature	1000VDC/AC RMS
Surge Protection: 8kV peak per IEC 61010	

2. **USE EXTREME CAUTION** when working with high voltages.
3. **DO NOT** measure voltage if the voltage on the "COM" input jack exceeds 1000V ground.
4. **NEVER** connect the meter leads across a voltage source while the function switch is in the current, resistance, or diode mode. Doing so can damage the meter.
5. **ALWAYS** discharge filter capacitors in power supplies and disconnect the power when making resistance or diode tests.
6. **ALWAYS** turn off the power and disconnect the test leads before opening the covers to replace the fuse or batteries.
7. **NEVER** operate the meter unless the back cover and the battery and fuse covers are in place and fastened securely.
8. If the equipment is used in a manner not specified by the manufacturer, the protection provided by the equipment may be impaired.

Features

- True RMS measures frequency, resistance, capacitance and temperature.
- Diode check and continuity functions.
- Backlit LCD readout with analog bar graph.
- 4-20 mA process loop measurements with % readout.
- Data hold, Max/Min and Peak capture mode.
- IP67 dust and waterproof.
- Cat. IV 600V, Cat. III 1000V safety rating.
- Includes Thermocouple Adapter, thermocouple wire probe (Type K), test leads, battery, weatherproof plugs, and carrying case.

Specifications

AC/DC Voltage

Range	AC: 400mV, 4, 40, 400, 1000V DC: 400mV, 4, 40, 400, 1000V
Accuracy	AC: 400mV $\pm(1.0\%$ rdg. + 5 dgt.) 4, 40, 400, 1000V $\pm(1.0\%$ rdg. + 3 dgt.) DC: 400mV/4,40,400V $\pm(0.06\%$ rdg. + 2 dgt.) 1000V $\pm(0.1\%$ rdg. + 5 dgt.)
Resolution	AC: 0.1mV, 0.001, 0.01, 1V DC: 0.01mV, 0.0001, 0.01, 0.1V

AC/DC Current

Range	400 Ω , 4, 40, 400k Ω , 4, 40M Ω
Accuracy	400 Ω : $\pm(0.3\%$ rdg. + 9 dgt.) 4, 40, 400k Ω , 4M Ω : $\pm(0.3\%$ rdg. + 4 dgt.) 40M Ω : $\pm(2.0\%$ rdg. + 10 dgt.)
Resolution	0.01 Ω , 0.0001, 0.001, 0.01k Ω , 0.001M Ω

NOTE: Accuracy is stated at 65°F to 83°F (18°C to 28°C) & less than 75%RH

continued ...

Capacitance

Range	40, 400nF, 4, 40, 400, 4000 μ F, 40mF
Accuracy	40, 400nF: $\pm(3.5\%$ rdg. + 40 dgt.) 4, 40, 400 μ F: $\pm(3.5\%$ rdg. + 10 dgt.) 4000 μ F, 40mF: $\pm(5\%$ rdg. + 10 dgt.)
Resolution	0.001, 0.01nF, 0.0001, 0.001, 0.01, 0.1 μ F, 0.001mF

Frequency

Range	40, 400Hz, 4, 40, 400kHz, 4, 40, 100MHz
Accuracy	$\pm(0.1\%$ rdg. + 1 dgt.)
Resolution	0.00, 0.01Hz, 0.0001, 0.001, 0.01kHz, 0.0001, 0.001, 0.01MHz

Temperature

Range	-58 to 1832°F (-50 to 1000°C)
Accuracy	$\pm(1.0\%$ rdg. + 4.5°F) $\pm(1.0\%$ rdg. + 2.5°C)
Resolution	1°F, 1°C

4-20mA%

Range	-25 to 125%
Accuracy	$\pm(50$ dgt.)
Resolution	0.01%

General Specifications

Range Selection	Autoranging/Manual
True RMS	Yes
Display	40,000 count LCD display
Display Hold	Yes
Max/Min	Yes
Peak Hold	Yes
Relative Mode	Yes
Diode Test	Yes

continued ...

Backlit Display	Yes
Digital Analog Bargraph	Yes
Continuity Check	Audible signal if resistance $\leq 35\Omega$
Duty Cycle	Yes (0.1 - 99.9%)
Kick Stand	Yes
Auto Power Off	Yes (after 15 minutes)
Power Supply	9V Battery
Low Battery Indicator	Yes
Fuse Protection	Yes
Replaceable Test Leads	Yes
Overvoltage Category	CAT. IV 600V, CAT. III 1000V
Product Certifications	CE, IP67, Drop Tested (2M)
Operating Temperature	41 to 104°F (5 to 40°C)
Storage Temperature	-4 to 140°F (-20 to 60°C)
Dimensions	7.4 x 3.2 x 2.0" (187 x 81 x 50mm)
Weight	12oz (342g)

NOTE: Accuracy specifications consist of two elements:

- (% reading) – This is the accuracy of the measurement circuit
- (+ digits) – This is the accuracy of the analog to digital converter

Enclosure	Double molded, waterproof
Shock (Drop Test)	6.5 feet (2 meters)
Temperature Sensor	Requires type K thermocouple
Input Impedance	$>10M\Omega$ VDC & $>3M\Omega$ VAC
AC True RMS	The term stands for "Root-Mean-Square", which represents the method of calculation of the voltage or current value. Average responding multimeters are calibrated to read correctly only on sine waves and they will read inaccurately on non-sine wave or distorted signals. True rms meters read accurately on either type of signal (includes holster)

continued ...

ACV Bandwidth	50Hz to 1000Hz
Crest Factor	≤3 at full scale up to 500V, decreasing linearly to ≤1.5 at 1000V
Overrange indication	"OL" is displayed
Auto Power Off	15 minutes (approximately) with disable feature
Polarity	Automatic (no indication for positive); Minus (-) sign for negative
Measurement Rate	2 times per second, nominal
Low Battery Indication	is displayed if battery voltage drops below operating voltage
Fuses	mA, μ A ranges; 0.5A/1000V ceramic fast blow A range; 10A/1000V ceramic fast blow
Operating Humidity	Max 80% up to 87°F (31°C) decreasing linearly to 50% at 104°F (40°C)
Storage Humidity	<80%
Operating Altitude	7000ft. (2000 meters) maximum
Safety	This meter is intended for origin of installation use and protected, against the users, by double insulation per EN61010-1 and IEC61010-1 2nd Edition (2001) to Category IV 600V & Category III 1000V; Pollution Degree 2. The meter also meets UL 61010-1, 2nd Edition (2004), CAN/CSA C22.2 No. 61010-1 2nd Edition (2004), & UL 61010B-2-031, 1st Edition (2003)
Optional Accessories	Adapter (AD-1) Replacement Fuses (F-500mA/1000V, F-10A/1000V) Thermocouple Probes (R2920, R2930, R2950, LS-109, TP-01) Test Leads (FC-300, R1000) Current Adapter (CP-09) Carrying Case (CA-05A)

Instrument Description

1. 40,000 count LCD display
2. REL button
3. RANGE button
4. MODE button
5. Function switch
6. mA, μ A and 10A input jacks
7. COM input jack
8. Positive input jack
9. HOLD and  (Backlight) button
10. PEAK button
11. MAX/MIN button

Note: Tilt stand and battery compartment are on back of unit.

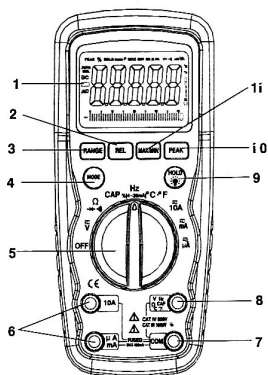

Display Description

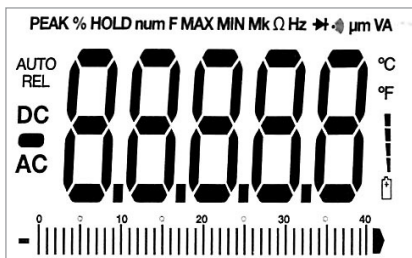

	Continuity		Diode test
	Battery status	n	nano (10 ⁻⁹) (capacitance)
μ	micro (10 ⁻⁶) (amps, cap)	m	milli (10 ⁻³) (volts, amps)
A	Amps	k	kilo (10 ³) (ohms)
F	Farads (capacitance)	M	mega (10 ⁶) (ohms)
Ω	Ohms	PEAK	Peak Hold
Hz	Hertz (frequency)	V	Volts
%	Percent (duty ratio)	REL	Relative
AC	Alternating current	AUTO	Autoranging
DC	Direct current	HOLD	Display hold
°F	Degrees Fahrenheit	°C	Degrees Centigrade
MAX	Maximum	MIN	Minimum

Operating Instructions

WARNING: Risk of electrocution. High-voltage circuits, both AC and DC, are very dangerous and should be measured with great care.

1. ALWAYS turn the function switch to the **OFF** position when the meter is not in use.
2. If "OL" appears in the display during a measurement, the value exceeds the range you have selected. Change to a higher range.

DC Voltage Measurement

CAUTION: Do not measure DC voltages if a motor on the circuit is being switched ON or OFF. Large voltage surges may occur that can damage the meter.

1. Set the function switch to the **V** $\overline{\text{DC}}$ position.
2. Insert the black test lead banana plug into the negative COM jack
Insert the red test lead banana plug into the positive V jack.
3. Touch the black test probe tip to the negative side of the circuit
Touch the red test probe tip to the positive side of the circuit.
4. Read the voltage in the display.

AC Voltage (Frequency, Duty Cycle) Measurement

WARNING: Risk of Electrocution. The probe tips may not be long enough to contact the live parts inside some 240V outlets for appliances because the contacts are recessed deep in the outlets.

As a result, the reading may show 0 volts when the outlet actually has voltage on it. Make sure the probe tips are touching the metal contacts inside the outlet before assuming that no voltage is present.



CAUTION: Do not measure AC voltages if a motor on the circuit is being switched ON or OFF. Large voltage surges may occur that can damage the meter.

continued ...

1. Set the function switch to the **Hz/%** position.
2. Insert the black test lead banana plug into the negative COM jack
Insert red test lead banana plug into the positive V jack.
3. Touch the black test probe tip to the neutral side of the circuit
Touch the red test probe tip to the "hot" side of the circuit.
4. Read the voltage in the display.
5. Press the **MODE** button to indicate "Hz".
6. Read the frequency in the display.
7. Press the **MODE** button again to indicate "%".
8. Read the % of duty cycle in the display.

DC Current Measurement



CAUTION: Do not make 20A current measurements for longer than 30 seconds. Exceeding 30 seconds may cause damage to the meter and/or the test leads.

1. Insert the black test lead banana plug into the negative COM jack.
2. For current measurements up to 4000 μ A DC, set the function switch to the **μ A**  position and insert the red test lead banana plug into the μ A/mA jack.
3. For current measurements up to 400mA DC, set the function switch to the **mA**  position and insert the red test lead banana plug into the μ A/mA jack.
4. For current measurements up to 20A DC, set the function switch to the **10A**  position and insert the red test lead banana plug into the 10A jack.
5. Press the **MODE** button to indicate "DC" on the display.
6. Remove power from the circuit under test, then open up the circuit at the point where you wish to measure current.
7. Touch the black test probe tip to the negative side of the circuit.
Touch the red test probe tip to the positive side of the circuit.
8. Apply power to the circuit.
9. Read the current in the display.

continued ...

AC Current (Frequency, Duty Cycle) Measurement



CAUTION: Do not make 20A current measurements for longer than 30 seconds. Exceeding 30 seconds may cause damage to the meter and/or the test leads.

1. Insert the black test lead banana plug into the negative COM jack.
2. For current measurements up to 4000 μ A AC, set the function switch to the **μ A**  position and insert the red test lead banana plug into the μ A/mA jack.
3. For current measurements up to 400mA AC, set the function switch to the **mA**  position and insert the red test lead banana plug into the μ A/mA jack.
4. For current measurements up to 20A AC, set the function switch to the **10A**  position and insert the red test lead banana plug into the 10A jack.
5. Press the **MODE** button to indicate "AC" on the display.
6. Remove power from the circuit under test, then open up the circuit at the point where you wish to measure current.
7. Touch the black test probe tip to the neutral side of the circuit
Touch the red test probe tip to the "hot" side of the circuit.
8. Apply power to the circuit.
9. Read the current in the display.
10. Press and hold the **MODE** button to indicate "Hz".
11. Read the frequency in the display.
12. Momentarily press the **MODE** button again to indicate "%".
13. Read the % duty cycle in the display.
14. Press and hold the **MODE** button to return to current measurement.

continued ...



Resistance Measurement

WARNING: To avoid electric shock, disconnect power to the unit under test and discharge all capacitors before taking any resistance measurements. Remove the batteries and unplug the line cords.



1. Set the function switch to the Ω   position.
2. Insert the black test lead banana plug into the negative COM jack
Insert the red test lead banana plug into the positive Ω jack.
3. Press the **MODE** button to indicate " Ω " on the display.
4. Touch the test probe tips across the circuit or part under test. It is best to disconnect one side of the part under test so the rest of the circuit will not interfere with the resistance reading.
5. Read the resistance in the display.

Continuity Check

WARNING: To avoid electric shock, never measure continuity on circuits or wires that have voltage on them.

1. Set the function switch to the Ω   position.
2. Insert the black lead banana plug into the negative COM jack
Insert the red test lead banana plug into the positive Ω jack.
3. Press the **MODE** button to indicate  and Ω on the display.
4. Touch the test probe tips to the circuit or wire you wish to check.
5. If the resistance is less than approximately 35Ω , the audible signal will sound. If the circuit is open, the display will indicate "OL".

Diode Test

1. Set the function switch to the Ω   position.
2. Insert the black test lead banana plug into the negative COM jack and the red test lead banana plug into the positive V jack.
3. Press the **MODE** button to indicate  and **V** on the display.
4. Touch the test probes to the diode under test. Forward voltage will typically indicate 0.400 to 0.700V. Reverse voltage will indicate "OL". Shorted devices will indicate near 0V and an open device will indicate OL in both polarities.

continued ...

Temperature Measurement

1. Set the function switch to the **Temp** position.
2. Insert the Temperature Probe into the input jacks, making sure to observe the correct polarity.
3. Press the **MODE** button to indicate **°F** or **°C**.
4. Touch the Temperature Probe head to the part whose temperature you wish to measure. Keep the probe touching the part under test until the reading stabilizes (about 30 seconds).
5. Read the temperature in the display.

Note: The temperature probe is fitted with a type K mini connector. A mini connector to banana connector adaptor is supplied for connection to the input banana jacks.

Capacitance Measurement

WARNING: To avoid electric shock, disconnect power to the unit under test and discharge all capacitors before taking any capacitance measurements. Remove the batteries and unplug the line cords.

1. Set the rotary function switch to the **CAP** position.
2. Insert the black test lead banana plug into the negative COM jack. Insert the red test lead banana plug into the positive V jack.
3. Touch the test leads to the capacitor to be tested.
4. Read the capacitance value in the display.

Frequency (Duty Cycle) Measurement (Electronic)

1. Set the rotary function switch to the **Hz/%** position.
2. Insert the black lead banana plug into the negative COM jack and the red test lead banana plug into the positive Hz jack.
3. Touch the test probe tips to the circuit under test.
4. Read the frequency on the display.
5. Press the **MODE** button to indicate "%".
6. Read the "%" duty cycle in the display.

continued ...

% 4 – 20mA Measurement

1. Set up and connect as described for DC mA measurements.
2. Set the rotary function switch to the 4-20mA% position.
3. The meter will display loop current as a % with 0mA=-25%, 4mA=0%, 20mA=100%, and 24mA=125%.

Autoranging/Manual Range Selection

When the meter is first turned on, it automatically goes into AutoRanging. This automatically selects the best range for the measurements being made and is generally the best mode for most measurements. For measurement situations requiring that a range be manually selected, perform the following:

1. Press the **RANGE** key. The "AUTO" display indicator will turn off.
2. Press the **RANGE** key to step through the available ranges until you select the range you want.
3. To exit the Manual Ranging mode and return to Autoranging, press and hold the **RANGE** key for 2 seconds.

Note: Manual ranging does not apply for the Temperature functions.

Max/Min

1. Press the **MAX/MIN** key to activate the MAX/MIN recording mode. The display icon "MAX" will appear. The meter will display and hold the maximum reading and will update only when a new "max" occurs.
2. Press the **MAX/MIN** key again and the display icon "MIN" will appear. The meter will display and hold the minimum reading and will update only when a new "min" occurs.
3. To exit MAX/MIN mode press and hold the **MAX/MIN** key for 2 seconds.

continued ...

Relative Mode

The relative measurement feature allows you to make measurements relative to a stored reference value. A reference voltage, current, etc. can be stored and measurements made in comparison to that value.

The displayed value is the difference between the reference value and the measured value.

Note: Relative mode does not operate in the 4-20mA function.

1. Perform the measurement as described in the operating instructions.
2. Press the **REL** button to store the reading in the display and the "REL" indicator will appear on the display.
3. The display will now indicate the difference between the stored value and the measured value.
4. Press the **REL** button to exit the relative mode

Display Backlight

Press the **HOLD**/ key for >1 second to turn the backlight on. The backlight will automatically turn off after 10 seconds.

Hold



The Hold function freezes the reading in the display. Press the **HOLD** key momentarily to activate or to exit the **HOLD** function.

Peak Hold

The Peak Hold function captures the peak AC voltage or current. The meter can capture negative or positive peaks as fast as 1 millisecond in duration. Momentarily press the **PEAK** button, "PEAK" and "MAX" will display. The meter will update the display each time a higher positive peak occurs. Press the **PEAK** button again, "MIN" will display. The meter will update the display each time a lower negative peak occurs. Press and hold the **PEAK** button for more than 1 second to exit Peak Hold mode. Auto Power Off feature will be disabled automatically in this mode.

continued ...

Low Battery Indication

With a fresh battery installed, the battery icon  with four lines above it will be displayed in the lower right corner of the LCD. The lines will disappear as the battery is used. When the  icon appears alone in the display, the battery should be replaced.

Auto Power Off

The auto off feature will turn the meter off after 15 minutes. To disable the auto power off feature, hold down the **MODE** button and turn the meter on. "APO d" will appear in the display. Turn the meter off and then on again to re-enable the auto power off feature.

Maintenance

WARNING: To avoid electric shock, disconnect the test leads from any source of voltage before removing the back cover or the battery or fuse covers.

WARNING: To avoid electric shock, do not operate your meter until the battery and fuse covers are in place and fastened securely. This MultiMeter is designed to provide years of dependable service, if the following care instructions are performed:

1. Keep the meter dry. If it gets wet, wipe it off.
2. Use and store the meter in normal temperatures.
Temperature extremes can shorten the life of the electronic parts and distort or melt plastic parts.
3. Handle the meter gently and carefully. Dropping it can damage the electronic parts or the case.
4. Keep the meter clean. Wipe the case occasionally with a damp cloth. Do not use chemicals, cleaning solvents, or detergents.
5. Use only fresh batteries of the recommended size and type. Remove old or weak batteries so they do not leak and damage the unit.
6. If the meter is to be stored for a long period of time, the batteries should be removed to prevent damage to the unit.

Battery Installation

WARNING: To avoid electric shock, disconnect the test leads from any source of voltage before removing the battery cover.

1. Turn power off and disconnect the test leads from the meter.
2. Open the rear battery cover by removing two screws (B) using a Phillips head screwdriver.
3. Insert the battery into battery holder, observing the correct polarity.
4. Put the battery cover back in place. Secure with the screws.

WARNING: To avoid electric shock, do not operate the meter until the battery cover is in place and fastened securely.

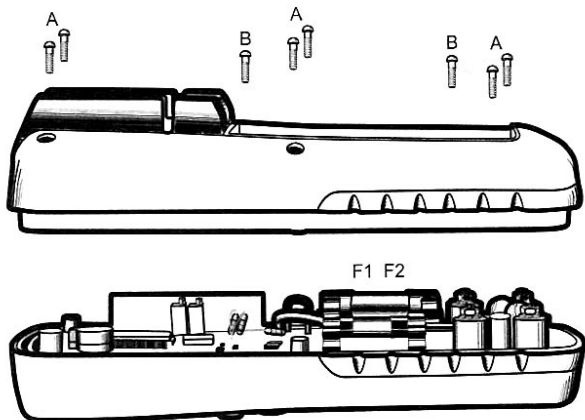

NOTE: If your meter does not work properly, check the fuses and batteries to make sure that they are still good and that they are properly inserted.

Replacing The Fuses

WARNING: To avoid electric shock, disconnect the test leads from any source of voltage before removing the meter cover.

1. Disconnect the test leads from the meter.
2. Remove the protective rubber holster.
3. Remove the battery cover (two "B" screws) and the battery.
4. Remove the six "A" screws securing the rear cover.
5. Gently remove the old fuse and install the new fuse into the holder.
6. Always use a fuse of the proper size and value (0.5A/1000V fast blow for the 400mA range [SIBA 70-172-40], 10A/1000V fast blow for the 20A range [SIBA 50-199-06]).
7. Replace and secure the rear cover, battery and battery cover.

WARNING: To avoid electric shock, do not operate your meter until the fuse cover is in place and fastened securely.

For service on this or any other REED product or information on other REED products, contact REED Instruments at info@reedinstruments.com.

Notes
