

R8085

REED INSTRUMENTS

Noise Dosimeter



Instruction Manual

www.REEDINSTRUMENTS.com

Table of Contents

Introduction	3
Product Quality.....	4
Safety	4
Features.....	4
Specifications.....	5-7
<i>Comparison of Frequency Weightings and Tolerance Limits.....</i>	<i>7</i>
<i>Time Weightings (Fast & Slow) Characteristics.....</i>	<i>7</i>
Included.....	7
Instrument Description	8
Display Description	9
%DOSE.....	9
<i>Sound Pressure Level (SPL).....</i>	<i>9</i>
Operating Instructions.....	10-11
<i>Power On/Off.....</i>	<i>10</i>
<i>Sound Pressure Level (dBA/dBC Mode).....</i>	<i>10</i>
<i>Data Hold.....</i>	<i>11</i>
<i>Recording Maximum and Minimum Readings.....</i>	<i>11</i>
<i>Backlighting</i>	<i>11</i>
What is Dose Noise Exposure?	11-15
<i>Noise Exposure (%DOSE) - Test Duration Mode.....</i>	<i>12-13</i>
<i>Noise Exposure (%DOSE) - Programmable Time Mode.....</i>	<i>13-15</i>
%DOSE Testing Notes:	15
Data Logging	15-16
<i>Sound Pressure Level (SPL) Data Recording Modes.....</i>	<i>15</i>
<i>SPL Manual Data Logging Mode</i>	<i>15-16</i>
<i>SPL Automatic Data Logging Mode</i>	<i>16</i>
Setup Mode.....	16-21
<i>Setting the Time and Date (dAtE).....</i>	<i>17</i>
<i>Setting the Data Logging Sampling Rate (SP-t).....</i>	<i>17</i>

continued...

<i>Enabling/Disabling Auto Power OFF (PoFF)</i>	17-18
<i>Setting the Criterion Level in dB (SEt LC)</i>	18
<i>Setting the Threshold in dB (SEt LT)</i>	18
<i>Setting the Exchange Rate in dB (SEt ER)</i>	18
<i>Checking Memory Space (SPC)</i>	19
<i>Clearing Stored Data (CLrE)</i>	19
<i>Verify Set Time, Date and Sampling Rate</i>	19
<i>Calibration Procedure</i>	19-20
<i>Data Stream Output</i>	20
<i>3.5mm Terminal to RS-232 Serial Connection</i>	21
Battery Replacement.....	21
Applications.....	21
Accessories and Replacement Parts	22
Appendix A: USA Regulations - OSHA Regulation	
Conversion Charts.....	22
Appendix B: Canada Regulations - Occupational Health and Safety	
Regulations, Occupational Exposure Limits	23
Appendix C: Noise Exposure Limits, by	
Canadian Jurisdiction.....	24
Appendix D: Regulations Conversion from "Percent Noise Exposure"	
or "DOSE" to "8-Hour Time-Weighted Average Sound Level" (TWA).....	25
Product Care	25
Product Warranty	26
Product Disposal and Recycling	26
Product Support.....	26

Introduction

Thank you for purchasing your REED R8085 Noise Dosimeter. Please read the following instructions carefully before using your instrument. By following the steps outlined in this manual your meter will provide years of reliable service.

Product Quality

This product has been manufactured in an ISO9001 facility and has been calibrated during the manufacturing process to meet stated product specifications. If a certificate of calibration is required please contact the nearest authorized REED distributor or authorized Service Center. Please note an additional fee for this service will apply.

Safety

Never attempt to repair or modify your instrument. Dismantling your product, other than for the purpose of replacing batteries, may cause damage that will not be covered under the manufacturer's warranty. Servicing should only be provided by an authorized service center.

Features

- Noise Dosimeter, Sound Level Meter and Data Logger
- High accuracy of ± 1.0 dB meets Type 2 standards
- Designed to meet noise survey requirements in compliance with OSHA and CCOHS regulations
- Personal sound exposure meets IEC 61252, ANSI S1.25
- A & C frequency weighting
- Fast & Slow time weighting
- Lightweight and compact design
- Adjustable Criterion Level, Exchange Rate and Threshold
- USB interface with Windows® compatible software to retrieve stored data (sold separately)
- Easy-to-read backlit LCD display
- Data hold and Min/Max hold
- Tripod mount for long-term monitoring
- Low battery indicator and auto shut off

Specifications

Measurement Type:	Sound Pressure Level: dB Personal Noise Exposure: %Dose
Measuring Range(s):	35 to 130dB Low: 35 to 80dB High: 80 to 130dB Auto: 35 to 130dB Dose: 70 to 130dB
Dynamic Range:	50dB (in each range)
Accuracy:	31.5Hz ± 3.0 dB, 63Hz ± 2.0 dB, 125Hz ± 1.5 dB, 250Hz ± 1.5 dB, 500Hz ± 1.5 dB, 1kHz ± 1.0 dB, 2kHz ± 2.0 dB, 4kHz ± 3.0 dB, 8kHz ± 5.0 dB
Resolution:	0.1dB
Response Time:	Approx. 1 second
Frequency Range:	31.5Hz to 8kHz
Frequency Weighting:	A, C
Time Weighting:	Fast/Slow (125mS and 1 second)
Microphone:	0.5" (12.7mm) electret condenser
Display:	4-digit LCD
Backlit Display:	Yes
Data Hold:	Yes
Min:	Yes
Max:	Yes
Alarm Indicators:	Over (visual on-screen)
Datalogging Capabilities:	Yes
Real-Time Clock and Date Stamp:	Yes
Selectable Sampling Rate:	Yes (1, 2, 5, 10, 30, 60, 120, 300, 600, 1800, 3600 seconds)

continued...

Selectable Dose	
Measurement Rate:	Yes (0, 1, 5, 10, 15, 30 minutes/ 1, 2, 4, 8, 10, 12, 24 hours)
Auto Shut-off:	Yes (after 10 minutes/off)
Tripod Mountable:	Yes
Low Battery Indicator:	Yes
Power Supply:	3 x AAA batteries
Output:	Yes, RS-232/USB (optional)
PC Connectivity:	USB Cable (R8085-USB, optional)
Software:	PC Software (R8085-PC, optional)
Software OS Compatibility:	Windows XP/Vista/7/8/10
Product Certifications:	CE, IEC61252, ANSI S1.25 for Noise Dose and Sound Exposure Meters, IEC 61672 Class 2/ANSI S1.4 Type S for Sound Level Meters
Operating Temperature:	32 to 122°F (0 to 50°C)
Storage Temperature:	14 to 140°F (-10 to 60°C)
Operating Humidity Range:	<85%
Dimensions:	4.2 x 2.3 x 1.0" (107 x 58 x 25mm)
Weight:	4.3oz (122g)

continued...

Comparison of Frequency Weightings and Tolerance Limits

Frequency Hz	A Weighting Characteristics	C Weighting Characteristics	Tolerance (IEC 61672 class 2)
31.5	-39.4dB	-3dB	±3.0dB
63	-26.2dB	-0.8dB	±2.0dB
125	-16.1dB	-0.2dB	±1.5dB
250	-8.6dB	0dB	±1.5dB
500	-3.2dB	0dB	±1.5dB
1K	0dB	0dB	±1.0dB
2K	+1.2dB	-0.2dB	±2.0dB
4K	+1dB	-0.8dB	±3.0dB
8K	-1.1dB	-3dB	±5.0dB

Time Weightings (Fast & Slow) Characteristics

Time Weighting Characteristics	Max Response Reference continuous Signal	Tolerance (IEC 61672 class 2)
F (Fast)	-1.0dB	±1.0dB
S (Slow)	-4.1dB	±1.0dB

Included

- Dosimeter
- Microphone with Clip
- Batteries
- Wrist Strap
- Carrying Case

Instrument Description

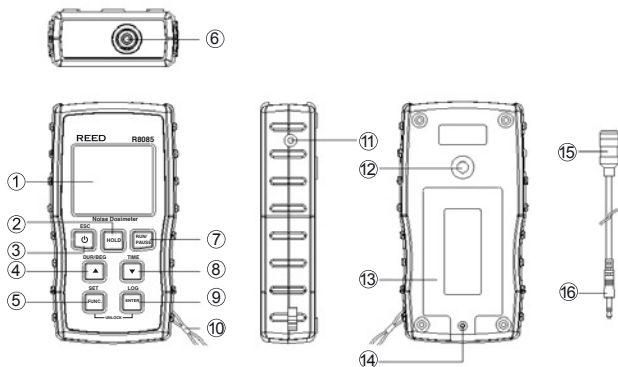

1. LCD Display
2. HOLD Button
3. Power/ESC/Backlight Button
4. Up/Duration/Begin/Fast/Slow/dB Range Button
5. FUNCTION/SET Button
6. Microphone Input Jack
7. RUN/PAUSE Button
8. Down/A/C/TIME Check Button
9. ENTER/LOG Button
10. Wrist Strap Anchoring Point
11. RS-232 Output Jack
12. Tripod Mounting Screw
13. Battery Cover
14. Battery Cover Screw
15. Microphone
16. Microphone Plug

Display Description

%DOSE

1. Test Duration, Start (BEG), Stop (END) Indicators
2. Locked Keypad Indicator
3. Test Duration Time Value
4. Time Stamp
5. Time Weighting Indicator
6. Unit of Measure
7. Frequency Weighting Indicator
8. Recording Status Indicator
9. %DOSE Measurement

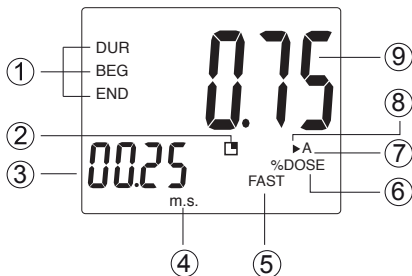

Sound Pressure Level (SPL)

1. dB Range Indicator
2. Time Weighting Indicator
3. Unit of Measure
4. Frequency Weighting Indicator
5. Sound Level Measurement
6. Max/Min Recording Indicator

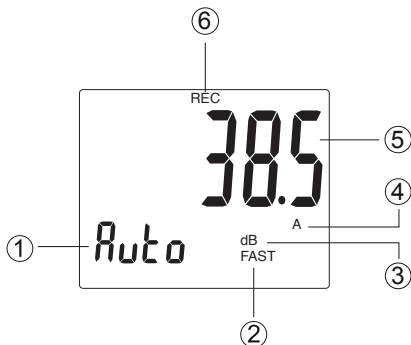

Operating Instructions

Power On/Off

Turn the meter on by pressing the POWER button. To turn the meter off, press and hold the POWER button for 2 seconds.

Sound Pressure Level (dBA/dBC Mode)

1. At start up, the meter's default settings are "Auto Range", "A Frequency Weighting" and "Fast Time Weighting".
2. Press and hold the ▲ button to select the desired Response Time. If the sound source consists of short bursts, set the response to FAST (125ms). To measure average sound level, select SLOW (1 second).
3. Press and hold the ▼ button to select the Frequency weighting. Select "A" Weighting for a general noise sound level, or "C" Weighting for measuring high level noise. "C" Weighting is a standard weighting of the audible frequencies commonly used for the measurement of Peak Sound Pressure Level. If the "C" Weighted level is much higher than the "A" Weighted level, then there will be a large amount of low-frequency noise.
4. Press the ▲ button to scroll through the three dB range types. There are two manual dB ranges to select from and an auto range. The manual ranges are described as follows:
Low (as indicated by "L"): 30 to 80dB range
High (as indicated by "H"): 80 to 130dB range
5. The meter can be held comfortably in one hand, placed in a pocket or positioned on a tripod for long-term monitoring.
6. Attach the microphone with the provided clip to an area where it will be exposed to sound levels (i.e. shirt collar).

Note: Set the cable in a way that does not hinder the working movements of the user. Direct contact with strong winds or blowing air on the microphone may cause measurement errors.

continued...

Data Hold

1. While taking a measurement, press the **HOLD** button to freeze the current readings on the display.
2. While in this mode a "HOLD" symbol will appear.
3. Press the **HOLD** button again to resume normal operation.

Note: When the Data Hold feature is active all buttons except the POWER button are disabled.

Recording Maximum and Minimum Readings

1. Press the **RUN/PAUSE** button to enter recording mode as indicated by "REC" on the LCD. The meter will now begin recording maximum and minimum readings.
2. While in recording mode:
 - A) Press the **RUN/PAUSE** button once and the maximum value will appear on the display as indicated by "REC MAX".
 - B) Press the **RUN/PAUSE** button again and the minimum value will appear on the display as indicated by "REC MIN".
 - C) To exit recording mode and resume normal operation, press and hold the **RUN/PAUSE** button for approx. two seconds.

Note: When in recording mode the POWER button is disabled and the meter cannot be turned off.

Backlighting

Press the BACKLIGHT button to turn the LCD Backlight on. It will automatically turn off after approx. 5 seconds.

The R8085 is designed to calculate and display an individual's noise exposure in %DOSE on the LCD display. All stored readings that are captured during the modes described in this manual can be accessed, and exported to Excel for further analysis by using the optional PC software (R8085-PC) and USB cable (R8085-USB).

What is Dose Noise Exposure?

The unit of measure, %DOSE, is used to quantify noise exposure that is measured during an employee's work shift. 100% dose is the maximum allowable noise exposure in accordance with OSHA, CCOHS, MSHA, DOD, ACGIH, and ISO standards. Most standards specify what specific Criterion Level, Exchange Rate, Response Time, and Frequency weighting the dosimeter should be set up with in order to meet these specific standards.

continued...

According to OSHA's noise standard, specifically, 29 CFR 1910.95, the dosimeter must be set up to record noise exposure using the following criteria:

- Exchange rate: 5dB
- Frequency weighting: A
- Response: Slow
- Criterion level: 90dBA (Hearing Conservation) or 90dBA (Administrative and Engineering Controls).
- Threshold: 80dBA (Hearing Conservation) or 90dBA (Administrative and Engineering Controls).

The Dosimeter allows for testing to begin immediately which is referred to as a Test Duration (DUR) or with programmable beginning and end times (BEG & END). Both modes are described in the following 2 sections.

Noise Exposure (%DOSE) - Test Duration Mode

1. Press the **FUNC.** button until you see SPL on the LCD.
2. Press and hold the **▲** button to select the desired Response Time.
3. Set the Criterion Level (Lc), Exchange Rate (ER), and Threshold Level (Lt) (see *Setup Mode* section for details).

Note: At start up, the meter's default settings are Lc → 90, Lt → 70, ER → 3.

4. Press the **FUNC.** button to enter the %DOSE mode. By default, the meter will be set to test duration (DUR).
5. Press and hold the **▼** button to set the duration time required for testing.
6. Use the **▲** and **▼** buttons to select between the following duration times:

24Hr	12Hr	10Hr	8Hr	4Hr
2Hr	1Hr	30 minutes	15 minutes	10 minutes
5 minutes	1 minute			

7. Press the **ENTER** button to confirm selection and return to the main screen.

Note: Make sure you have enough memory to complete your noise survey (see *Clear Stored Data in Setup Mode* section for details).

8. The meter can be placed in a pant or shirt pocket.

continued...

9. Clip the microphone as close as possible to the user's ear
i.e. shirt collar.

Note: Set the cable in a way that does not hinder the user's ability to perform their tasks.

10. Press the **RUN/PAUSE** button to begin measuring accumulated noise exposure.

Note: When recording begins or is restarted all buttons except the Backlight button are locked.

11. The elapsed duration timer will start automatically and "DUR" will flash on the LCD display confirming test duration has begun.
12. To pause a recording, first unlock the keypad by pressing the **FUNC.** and **ENTER** buttons simultaneously and then press the **RUN/PAUSE** button. The pause icon **||** will appear confirming testing is now paused while both the DUR icon will stop flashing.
13. Press the **RUN/PAUSE** button again to resume testing.
14. When the duration time is reached, "DUR" will stop flashing and the final accumulated noise exposure value is displayed.
15. To erase the previous accumulated %DOSE value and start a new duration test, press the **FUNC.** and **ENTER** buttons simultaneously.
16. Press the **FUNC.** button to resume normal operation.

Noise Exposure (%DOSE) - Programmable Time Mode

This mode allows testing to begin and end at user selected times. It is strongly advised to set the correct date and time before proceeding (see *Setting the Time and Date in Setup mode* section for details).

1. Press the **FUNC.** button until you see SPL on the LCD.
2. Press and hold the **▲** button to select the desired Response Time.
3. Set the Sampling Rate, Criterion Level (Lc), Exchange Rate (ER), and Threshold Level (Lt) (see *Setup Mode* section for details).

Note: At start up, the meter's default settings are Sampling Rate → 2 sec., Lc → 90, Lt → 70, ER → 3.

4. Press the **FUNC.** button to enter the %DOSE mode. By default, the meter will be set to test duration (DUR).
5. Press and hold the **▲** button to switch to programmable mode as indicated by "BEG" on the LCD.

continued...

6. Press and hold the ▼ button to set the recording start time.
7. Use the ▲ and ▼ buttons to adjust the current date as indicated by "dd".
8. Press the **FUNC.** button to confirm selection and switch to the hour digit as indicated by "h".
9. Use the ▲ and ▼ buttons until the desired number value is reached.
10. Press the **FUNC.** button to confirm selection and switch to the minutes digit as indicated by "m".
11. Use the ▲ and ▼ buttons until the desired number value is reached.
12. Press the **ENTER** button to save your selection and skip to the recording end time parameter as indicated by "END" on the LCD.
13. Repeat steps 6 through 10 to set the recording end time.
14. Press the **ENTER** button to save your selection and return to the main screen.

Note: Make sure you have enough memory to complete your noise survey (see *Clear Stored Data in Setup Mode* section for details).

15. The meter can be placed in a pant or shirt pocket.
16. Clip the microphone as close as possible to the user's ear i.e. shirt collar.

Note: Set the cable in a way that does not hinder the user's ability to perform their tasks.

17. Press and hold the **LOG** button to enter automatic data logging mode for SPL recordings as indicated by "LOGGER" on the LCD.
18. Press the **RUN/PAUSE** button to activate the programmed start and end times.
19. The keypad will automatically lock and the meter will start measuring once the programmed start time is reached.
20. When started, "DUR" will flash on the LCD display confirming programmed testing has begun while "LOGGER" will flash every time a SPL reading is stored at the user selected sampling rate.
21. To pause a recording, first unlock the keypad by pressing the **FUNC.** and **ENTER** buttons simultaneously and then press the **RUN/PAUSE** button. The pause icon **||** will appear confirming testing is now paused while both the DUR and LOGGER icons will stop flashing.

continued...

22. Press the **RUN/PAUSE** button again to resume testing.
23. When the end time is reached, both the DUR and LOGGER icons will stop flashing and the final accumulated noise exposure value is displayed.
24. To end the current session, first unlock the keypad again and press and hold the **ENTER** button for 2 seconds.
25. Press the **FUNC.** button to resume normal operation.

%DOSE Testing Notes:

- Never shout into the microphone as this will affect the test results.
- Microphone should not come into contact with any objects during recording to avoid erroneous test results.
- For best results, test over the course of several days and average the %DOSE.

Data Logging

Sound Pressure Level (SPL) Data Recording Modes

Manual Data Logging: Manually log readings into the internal memory (see *Manual Data Logging Mode* section for details).

Automatic Data Logging: Setup the meter parameters in order to automatically log data into the internal memory.

Note: The meter can store up to 16,000 data points and will indicate "FULL" on the LCD display when this amount is exceeded.

Please note to use the data logging feature for Sound Level Pressure (SPL) the optional PC software (R8085-PC) and USB cable (R8085-USB) are required. With the software, all stored readings that are captured can be downloaded and exported to Excel for further analysis.

SPL Manual Data Logging Mode

In manual mode the **LOG** button is pressed to manually log a reading into the internal memory at any time. In order to setup the meter for manual data logging, follow steps 1 through 4 below.

1. Set the data logging sampling rate to "0" seconds.
2. Press and hold the **LOG** button to enter manual data logging mode.
3. Press the **LOG** button to save a reading to memory. "LOGGER" will flash each time a data point is stored.

continued...

4. To exit manual data logging mode, press and hold the **LOG** button for 2 seconds to resume normal operation.

SPL Automatic Data Logging Mode

In automatic mode, the desired data logging sampling rate is set to 1, 2, 5, 10, 30, 60, 120, 300, 600, 1800 or 3600 seconds prior to recording.

In order to setup the meter for automatic data logging, follow steps 1 through 5 below.

1. Press and hold the **LOG** button to enter automatic data logging mode.
2. The "LOGGER" will flash every time a reading is stored at the user selected sampling rate.
3. To pause the data logging session press the **LOG** button and **LOGGER** will stop flashing.
4. To resume press the **LOG** button again.
5. To end the current data logging session, press and hold the **LOG** button for 2 seconds to resume normal operation.

Setup Mode

1. Press and hold the **FUNC.** button for 2 seconds to enter Setup Mode.
2. Press the **FUNC.** button continuously to scroll through the following parameters.

Parameter	Description
dAtE	Set the time and date
SP-t	Set the data logging sampling rate
PoFF	Enable or disable the auto-power off
SEt LC	Set Criterion level in dB
SEt LT	Set Threshold in dB
SEt ER	Set Exchange rate in dB
SPC	Check Memory space
CLrE	Clear Stored Data

continued...

3. Once the appropriate parameter has been selected follow the associated instructions below.

Note: The meter automatically exits out of the Setup mode if no key is pressed within 7 seconds.

Setting the Time and Date (dAtE)

1. Press the **ENTER** button when the dAtE parameter appears on the LCD.
2. Use the ▲ and ▼ buttons to adjust the year as indicated by "YY".
3. Press the **ENTER** button to confirm selection.
4. Repeat steps 2 and 3 for month, day, hour, minute and seconds as indicated by (mm./dd/h./m./s).
5. After each value has been selected and confirmed, it will automatically skip to the next parameter.

Note: At any time, you can press the ESC button to exit the Setup mode and resume normal operation. The internal clock will keep accurate time when the meter is powered off. When new batteries are installed the clock will have to be reset.

Setting the Data Logging Sampling Rate (SP-t)

Follow steps 1 and 2 when "SP-t" appears on the LCD.

1. Use the ▲ and ▼ buttons to adjust the sampling rate between 0, 1, 2, 5, 10, 30, 60, 120, 300, 600, 1800, and 3600 seconds.
2. Press the **ENTER** button to confirm selection and skip to next parameter.

Note: At any time, you can press the ESC button to exit the Setup mode and resume normal operation.

Enabling/Disabling Auto Power OFF (PoFF)

Follow steps 1 and 2 when "PoFF" appears on the LCD.

1. Use the ▲ and ▼ buttons to select between ON (enabled) or OFF (disabled). With the Auto Power OFF feature enabled, the meter will automatically switch OFF after 10 minutes of inactivity to preserve battery life.

continued...

2. Press the **ENTER** button to confirm selection and skip to next parameter.

Note: At any time, you can press the ESC button to exit the Setup mode and resume normal operation.

Setting the Criterion Level in dB (SEt LC)

Follow steps 1 and 2 when "SEt LC" appears on the LCD.

1. Use the ▲ and ▼ buttons to adjust the criterion level between 80, 84, 85, and 90 dB.
2. Press the **ENTER** button to confirm selection and skip to next parameter.

Note: At any time, you can press the ESC button to exit the Setup mode and resume normal operation.

Setting the Threshold in dB (SEt LT)

Follow steps 1 and 2 when "SEt LT" appears on the LCD.

1. Use the ▲ and ▼ buttons to adjust the threshold which can be set anywhere between 70 and 90 dB.
2. Press the **ENTER** button to confirm selection and skip to next parameter.

Note: At any time, you can press the ESC button to exit the Setup mode and resume normal operation.

Setting the Exchange Rate in dB (SEt ER)

Follow steps 1 and 2 when "SEt ER" appears on the LCD.

1. Use the ▲ and ▼ buttons to adjust the threshold which can be set between 3, 4, 5 and 6 dB.
2. Press the **ENTER** button to confirm selection and skip to next parameter.

Note: At any time, you can press the ESC button to exit the Setup mode and resume normal operation.

continued...

Checking Memory Space (SPC)

When "SPC" appears on the LCD, the upper part of the display will indicate the remaining datapoints available to record.

Clearing Stored Data (CLrE)

Follow steps 1 through 5 when "CLrE" appears on the LCD.

1. Use the ▲ and ▼ buttons to select between Yes (Clear data) or No (Abort).
2. Press the **ENTER** button to confirm selection.

Note: If "No" is selected, the meter will skip to the next parameter.

3. If "Yes" is selected, press the **ENTER** button again to re-confirm.
4. The meter will clear all stored data and automatically skip to the next parameter when complete.
5. When all parameters have been set up, press the ESC button to exit the Setup mode and resume normal operation.

Verify Set Time, Date and Sampling Rate

During normal operation press the **TIME** button to display the year, month, day, hour, minutes, and selected sampling rate.

Calibration Procedure

In order to calibrate the R8085, an external calibrator that can provide a 94.0dB signal is required (REED R8090). If the meter has been exposed to extreme conditions or has not been used in a long period of time the meter should be calibrated by following steps 1 through 11 below.

1. Power on the meter.
2. Press the **FUNC.** button to ensure you are in SPL mode.
3. Select "80 - 100dB" (Hi) range.
4. Select "FAST" time weighting.
5. Select "A" weighting.
6. Insert Microphone into the sound calibrator's microphone adapter.
7. Power on the sound calibrator (R8090).

Note: If the measured value is not within "94 ±0.2" dB, adjust the meter's calibration by entering calibration mode.

continued...

8. Press and hold the **HOLD** and **RUN/PAUSE** buttons simultaneously for approx. 3 seconds to enter calibration mode.
9. When in calibration mode, the current sound level measurement will appear on the lower and upper part of the LCD display.
10. Press the **▲** and **▼** buttons to adjust the upper display until it matches the output of the calibrator (94.0dB).
11. Once the calibration is complete, press **ENTER** button to save the calibration value into the memory which will flash confirming it has been saved.
12. Press the **FUNC.** button to exit the calibration mode and resume normal operation.

Data Stream Output

Using Terminal application, a data stream can be viewed from the RS-232 output, Connect the RS-232/USB cable between the product and terminal/PC and use the following setting to view the data stream.

Terminal Settings:

- Bits per second: 9600
- Data bits: 8
- Parity: None
- Stop bits: 1

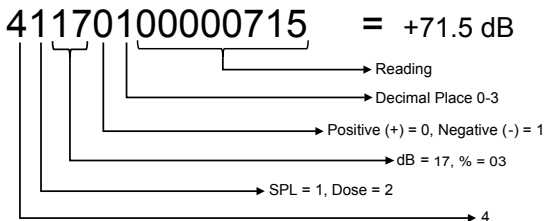

continued...

3.5mm Terminal to RS-232 Serial Connection

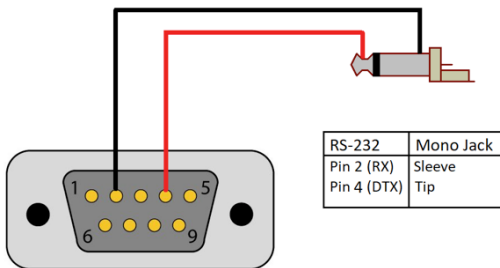

Battery Replacement

When the low battery icon  appears on the LCD, the batteries must be replaced.

1. Remove the Phillips screw located on the back of the meter.
2. Remove the battery cover.
3. Replace the 3 x "AAA" batteries.
4. Secure the battery cover and tighten the screw.

Applications

- Personal Accumulated Noise Exposure
- Preventative Maintenance
- Industrial Machinery/Equipment
- Construction Sites
- Ensuring Safe Working Conditions
- Public Venues / Concerts
- Code Enforcement
- Traffic
- Appliance Noise Testing
- Recording of Acoustic Levels for Environmental Impact Studies

Accessories and Replacement Parts

- **R8085-PC** PC Software for Noise Dosimeter
- **R8085-USB** USB Cable for Noise Dosimeter
- **CA-52A** Soft Carrying Case
- **R8888** Hard Carrying Case
- **R8090** Sound Level Calibrator
- **R1500** Tripod

Don't see your part listed here? For a complete list of all accessories and replacement parts visit your product page on www.reedinstruments.com.

Appendix A: USA Regulations - OSHA Regulation Conversion Charts

OSHA Permissible Noise Exposures Duration per day, hours	Sound level dBA, slow response
8	90
6	92
4	95
3	97
2	100
1.5	102
1	105
0.5	110
0.25 or less	115

Source: 29 CFR 1910 Table G-16

For up-to-date information, please visit
https://www.osha.gov/dts/osta/otm/new_noise/#standards

continued...

Appendix B: Canada Regulations - Occupational Health and Safety Regulations, Occupational Exposure Limits

Table 1A
Noise Exposure Limits when Criterion Level = 90 dB(A)

3 dB(A) Exchange Rate	Maximum Permitted Daily Duration (hours)	5 dB(A) Exchange Rate
Allowable Level dB(A)		Allowable Level dB(A)
90	8	90
93	4	95
96	2	100
99	1	105
102	0.5	110
105	0.25	115

Table 1B
Noise Exposure Limits when Criterion Level = 85 dB(A)

3 dB(A) Exchange Rate	Maximum Permitted Daily Duration (hours)	5 dB(A) Exchange Rate
Allowable Level dB(A)		Allowable Level dB(A)
85	8	85
88	4	90
91	2	95
94	1	100
97	0.5	105
100	0.25	110

continued...

Appendix C: Noise Exposure Limits, by Canadian Jurisdiction

Jurisdiction (federal, provincial, territorial)	Continuous Noise	
	Maximum Permitted Exposure Level for 8 Hours: dB(A)	Exchange Rate dB(A) +
Canada (Federal)	87	3
British Columbia	85	3
Alberta	85	3
Saskatchewan	85	3
Ontario	85	3
Quebec	90	5
New Brunswick	85	3
Nova Scotia	85	3
Prince Edward Island	85	3
Newfoundland and Labrador	85	3
Northwest Territories	85**	***
Nunavut	85**	***
Yukon Territories	85	3

** In Nunavut and Northwest Territories, the Occupational Health and Safety Regulations reference a staged action plan based on the dBA exposure level (80, 85, and 90).

*** In both territories, the Mining Health and Safety Regulations reference 3 dBA. Please contact Northwest Territories and/or Nunavut for further information.

For up-to-date information, please visit:

https://www.ccohs.ca/oshanswers/phys_agents/noise_measurement.html

continued...

Appendix D: Regulations Conversion from "Percent Noise Exposure" or "DOSE" to "8-Hour Time-Weighted Average Sound Level" (TWA)

Dose or Percent	TWA (dBA)	Dose or Percent	TWA (dBA)
10	73.4	70	87.4
15	76.3	75	87.9
20	78.4	80	88.4
25	80.0	85	88.8
30	81.3	90	89.2
35	82.4	95	89.6
40	83.4	100	90.0
45	84.2	105	90.4
50	85.0	110	90.7
55	85.7	115	91.1
60	86.3	120	91.3
65	86.9	125	91.6

Note: 5-dB exchange rate and 90-dBA Criterion

Product Care

To keep your instrument in good working order we recommend the following:

- Store your product in a clean, dry place.
- Change the battery as needed.
- If your instrument isn't being used for a period of one month or longer please remove the battery.
- Clean your product and accessories with biodegradable cleaner. Do not spray the cleaner directly on the instrument. Use on external parts only.

Product Warranty

REED Instruments guarantees this instrument to be free of defects in material or workmanship for a period of one (1) year from date of shipment. During the warranty period, REED Instruments will repair or replace, at no charge, products or parts of a product that proves to be defective because of improper material or workmanship, under normal use and maintenance. REED Instruments total liability is limited to repair or replacement of the product. REED Instruments shall not be liable for damages to goods, property, or persons due to improper use or through attempts to utilize the instrument under conditions which exceed the designed capabilities. In order to begin the warranty service process, please contact us by phone at 1-877-849-2127 or by email at info@reedinstruments.com to discuss the claim and determine the appropriate steps to process the warranty.

Product Disposal and Recycling



Please follow local laws and regulations when disposing or recycling your instrument. Your product contains electronic components and must be disposed of separately from standard waste products.

Product Support

If you have any questions on your product, please contact your authorized REED distributor or REED Instruments Customer Service by phone at 1-877-849-2127 or by email at info@reedinstruments.com.

Please visit www.REEDINSTRUMENTS.com for the most up-to-date manuals, datasheets, product guides and software.

*Product specifications subject to change without notice.
All rights reserved. Any unauthorized copying or reproduction of this manual is strictly prohibited without prior written permission from REED Instruments.*

REED

INSTRUMENTS

TEST & MEASURE WITH CONFIDENCE



CHECK OUT OUR LATEST PRODUCTS!

www.REEDINSTRUMENTS.com

REED INSTRUMENTS

TEMPERATURE
& HUMIDITY



SOUND



MOISTURE



AIR VELOCITY



ELECTRICAL



www.REEDINSTRUMENTS.com